

MY SPACE

PONTI + CASTELLI + SOPPALCHI

**Fantasia
e praticità**

GLOBO_VEGA

night collection

**rinnovano
gli spazi della
camera
con soluzioni
tecniche
creative**

SPAGNOLmobili

concept
my
Space

PER OTTIMIZZARE
GLI SPAZI

PROGRAMMA GLOBO - VEGA

—
Progetti per camere fantasiose e pratiche, soluzioni tecniche per idee innovative: la camera dei ragazzi diventa un laboratorio di creatività e dà più valore a ogni tipologia di spazio.

—
Projects for imaginative and practical rooms, technical solutions for innovative ideas: the kids room becomes a laboratory of creativity and gives more value to each type of space.

SPAGNOLmobili

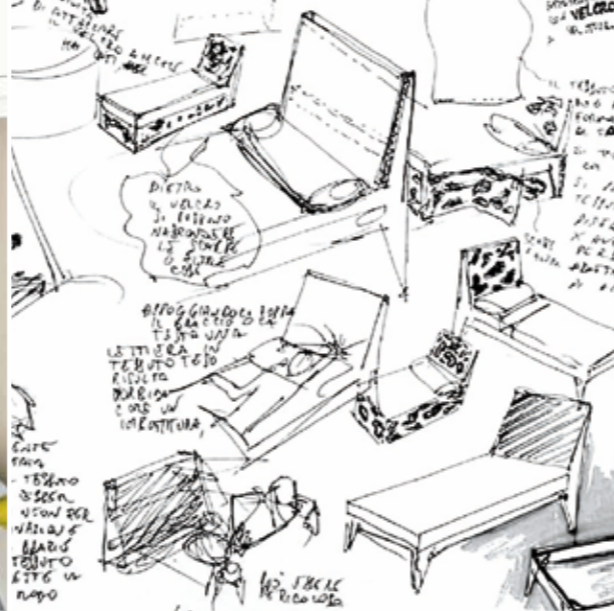

The projects Spagnol for kids' rooms are born from a continuous research on materials, technical solutions and safety combined with innovation aesthetic to interpret the styles of the new generation.

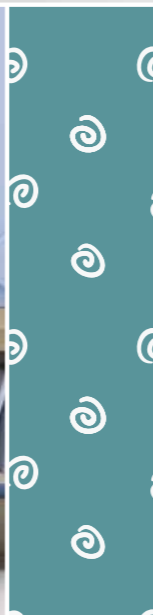
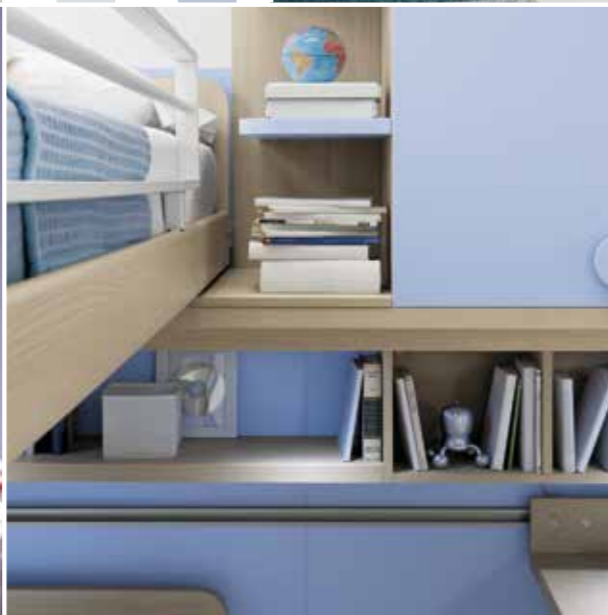

I PROGETTI
SPAGNOL PER
LE CAMERE
DEI RAGAZZI
NASCONO DA
UNA CONTINUA
RICERCA SUI
MATERIALI,
LE SOLUZIONI
TECNICHE E LA
SICUREZZA UNITA
ALL'INNOVAZIONE
ESTETICA PER
INTERPRETARE
GLI STILI
DELLE NUOVE
GENERAZIONI

48 Colori laccati opachi

29 Colori laccati lucidi



48 mat lacquered colors, 29 glossy lacquered colors

Una grande tavolozza di colori per dare spazio alla fantasia e alle emozioni con le tinte più moderne, allegre e vivaci oppure serene e rilassanti.

A large palette of colors to give space to the imagination and emotions with the most modern colors, cheerful and lively or serene and relaxing.

6 Finiture nobilitato per le strutture

6 melamine finishes for structure

Il calore del legno in diverse sfumature per ambienti luminosi o con un tocco classico. Un materiale resistente per dare sicurezza, praticità e stile.

The warmth of wood in different shades for bright rooms or with a classic touch. A durable material to give security, convenience and style

16 Finiture nobilitato per frontali Spazio

16 melamine finishes for Spazio doors



100% Tessuti in cotone anallergici

100% hypoallergenic cotton fabrics

La morbidezza delle trame di cotone e la bellezza naturale dei colori. I tessuti creano un'atmosfera piacevole, accogliente e soprattutto di alta qualità.

The softness of the textures of cotton and the natural beauty of the colors. The fabrics create a pleasant atmosphere, friendly and above all of high quality

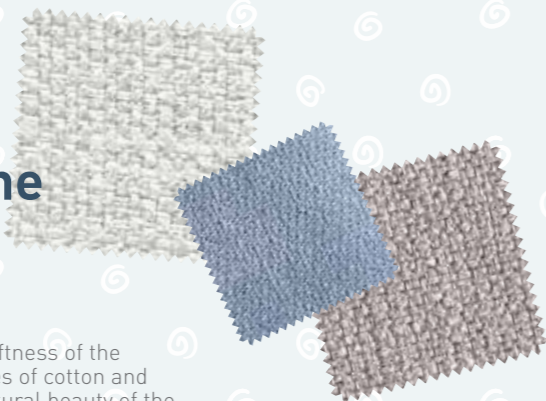

LIBERA LA TUA CREATIVITÀ CON LE COMBINAZIONI DI COLORI E MATERIALI

Set free your creativity with the combination of colors and materials



08

programma

GLOBO_VEGA

PONTI + CASTELLI + SOPPALCHI
BRIDGE + CASTLE + MEZZANINES

—
Storage with shoulder modularity for open spaces, sliding beds or on wheels, bridge structures: all the solution can be combined to create your ideal room, single or double, coloured and bright.

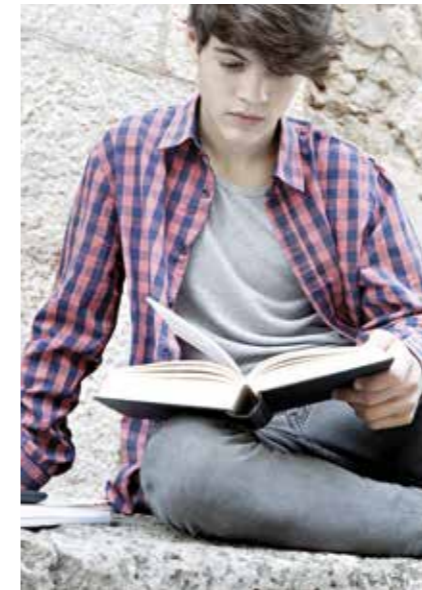

CONTENITORI,
SISTEMI
A SPALLA
PER VANI A
GIORNO, LETTI
SCORREVOLI
E SU RUOTE,
STRUTTURE
A PONTE:
LE SOLUZIONI
SI INTEGRANO
PER CREARE
LA TUA
CAMERA IDEALE,
SINGOLA
O DOPPIA,
LUMINOSA
E COLORATA



201

Composizione
Composition



Scaletta Toy
in legno

Tutto su una parete.
Gli elementi si
integrano in una
composizione
completa che segue
un progetto preciso.

All on one wall.
The elements are
integrated into a
complete composition
that follows a
specific project.



Scaletta Toy in legno

Wooden ladder Toy

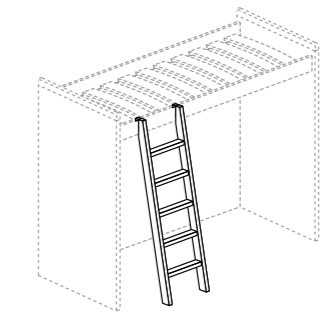

Finiture disponibili: in tutti i colori laccati opachi
Only available in matt lacquer as color



201

Composizione
Composition

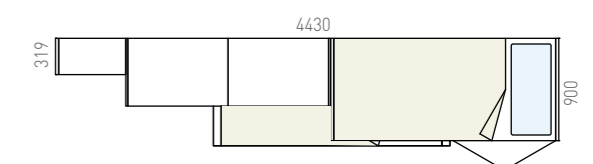

202

Composizione
Composition





**Protezione
Timber**

Le nuove protezioni reclinabili

The new reclining protections

Oltre a proteggere il tuo bambino, sbloccando l'apposito perno la protezione può essere aperta per facilitare il riassetto del letto.

In addition to protecting your child, unlocking the special stud protection can be opened to facilitate the reorganization of the bed.



Protezione Timber in metallo

Finiture disponibili: alluminio o bianco
Available finishes: aluminum or white



Protezione Toy in mdf

Finiture disponibili: in tutti i colori laccati opachi
Only available in matt lacquer as color



202

Composizione
Composition

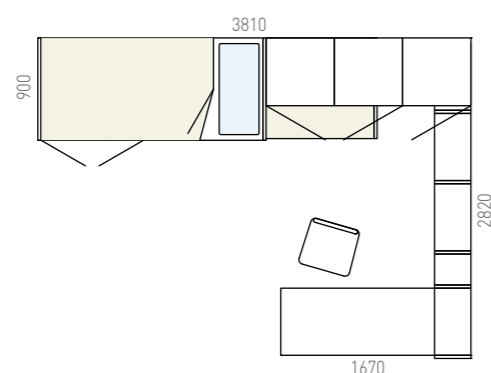
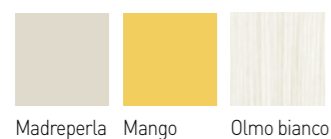



203

Composizione
Composition



Tassello Maxi

Coordinare i colori, unire le forme e inventare soluzioni come il doppio letto da utilizzare ogni giorno

Coordinate the colors, join forms and invent solutions such as double bed to use every day

Le idee creano l'ambiente, dai ripiani a giorno del terminale al pensile libreria, dal fianco colorato dei letti alla scrivania.

The ideas create the environment, from the open shelves of the cabinet to the wall unit bookcase, from the colored side of the bed to the desk.



Maniglia Tassello Maxi

Handle Tassello Maxi

Finiture disponibili: olmo bianco / canapa / urbano / montego e tutti i colori laccati opachi
Available finishes: olmo bianco / canapa / urbano / montego and all the matt lacquered colors

H 182 cm [per anta H 191,6]
H 214 cm [per anta H 223,6]
H 246 cm [per anta H 255,6]



203

Composizione
Composition

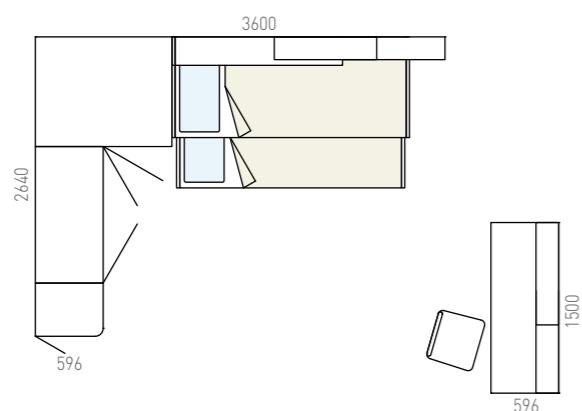
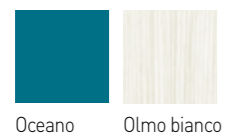

Pensili componibili Tetris da 60 / 90 / 120 cm



204

Composizione
Composition



*** Elemento terminale per ponte**

Terminal element for bridge

Finiture disponibili: nobilitato bianco / madreperla / olmo bianco / canapa / urbano / montego e tutti i colori laccati opachi
 Available finishes: melamine bianco / madreperla / olmo bianco / canapa / urbano / montego and all the matt lacquered colors

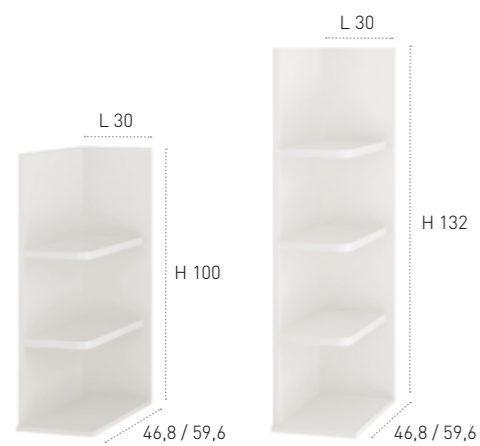

204

Composizione
 Composition

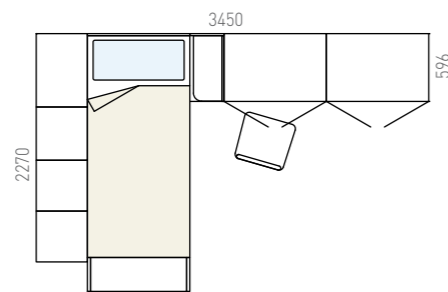
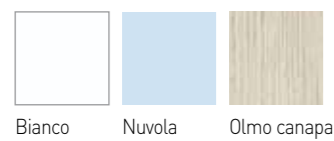

Elemento terminale per ponte



205

Composizione
Composition



La versatilità del programma consente innumerevoli soluzioni, anche con un grande armadio e i letti ad angolo.

The versatility of the program allows multiple solutions, even with a big closet and the corner beds.



Fianco libreria

*** Fianco libreria prof. 29,8 cm**

Library side depth 29,8 cm

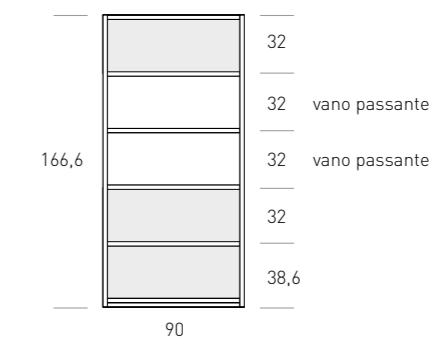

Finiture disponibili: nobilitati bianco / madreperla / olmo bianco / canapa / urbano / montego e tutti i colori laccati opachi
 Available finishes: melamine bianco / madreperla / olmo bianco / canapa / urbano / montego and all the matt lacquered colors

205

Composizione
Composition

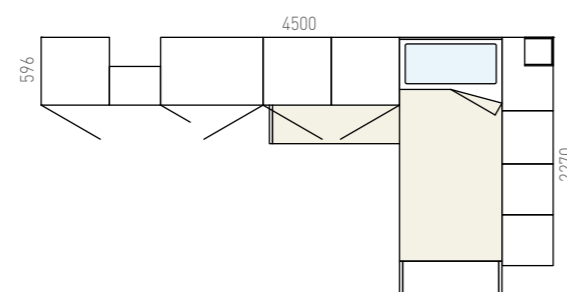
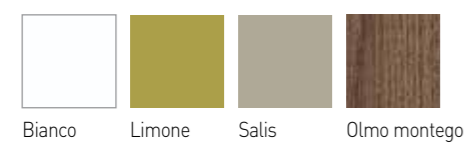

206

Composizione
Composition





Colonna a giorno sottoponte

I colori tenui creano un'atmosfera un po' romantica, una camera dove si sogna anche di giorno... con la fantasia!

The soft colors create an atmosphere a bit romantic, a bedroom where it is possible to dream even in the daytime ... with the imagination!



206

Composizione
Composition

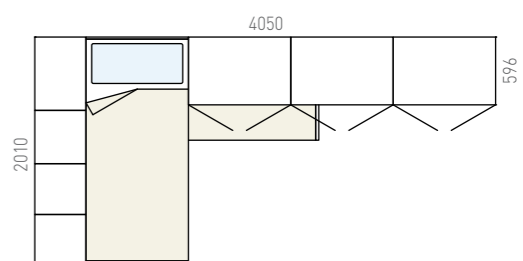

207

Composizione
Composition





**Si progetta in base
allo spazio disponibile
sapendo che ci sarà
sempre una soluzione
per le vostre esigenze**

We design on the based on the available space
knowing that there will always a solution for your needs

Salire a letto
con la scaletta è
sicuramente più
avventuroso.
E sulle mensole ci
stanno i tuoi libri.

Climb into bed with
ladder is definitely
more adventurous.
There is more space
your books on the
shelves.

207

Composizione
Composition

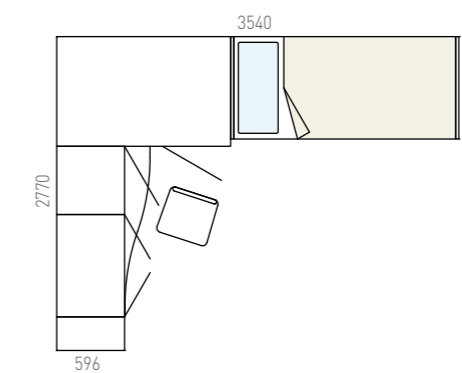
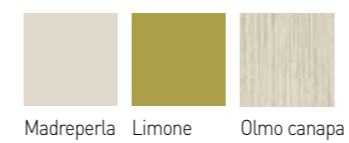



208

Composizione
Composition



Pannello protezione per scaletta

Protection panel for ladder

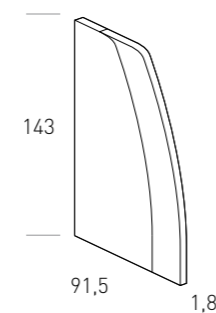

Finiture disponibili: nobilitati bianco / madreperla / olmo bianco / canapa / urbano / montego e tutti i colori laccati opachi
 Available finishes: melamine bianco / madreperla / olmo bianco / canapa / urbano / montego and all the matt lacquered colors

Le cabine ottimizzano lo spazio creando aree ideali per il giorno e la notte

The walk-in closet optimize your space creating ideal areas for the day and the night

In una camera per ragazzi anche il progetto è creativo: un appassionante gioco di volumi, di colori e di forme.

In a room for kids also the project is creative: an exciting game of volumes, colors and shapes.

208

Composizione
Composition

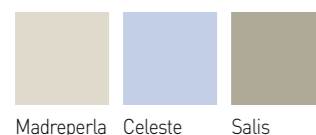

Madreperla Celeste Salis

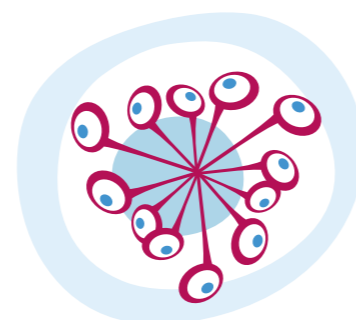
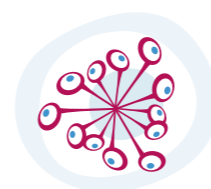
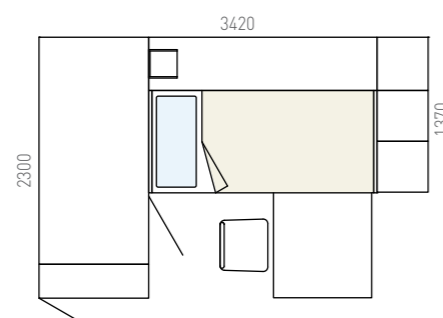

Pannello protezione scaletta

209

Composizione
Composition





Integrare le funzioni, colorare gli spazi

Integrat the functions, colors the spaces

La composizione termina con la spaziosa cabina armadio che nasconde una grande capacità contenitiva.

The composition ends with a spacious wardrobe unit that hides a large storage capacity.

209

Composizione
Composition



Pomodoro Olmo bianco

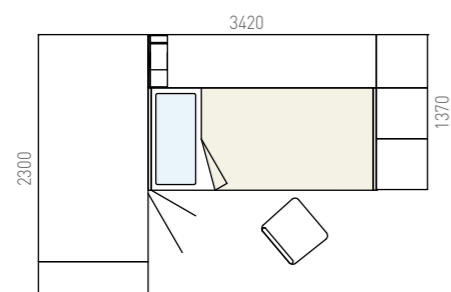

210

Composizione
Composition





Soluzioni multifunzionali

Multifunctional solutions

Un'area per la notte super attrezzata e una zona per lo studio con la libreria che si sviluppa sulla parete liberamente.

An area super-equipped for the night and an area for the study with the library that develops itself freely on the wall.



210

Composizione
Composition

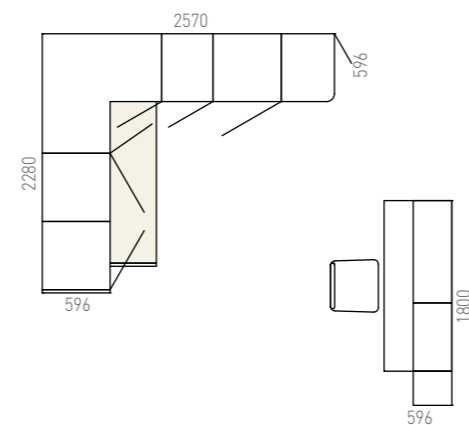
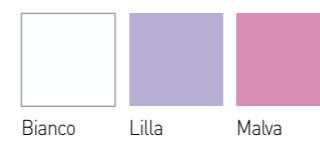

Pensili 1.2
con anta e vano
a giorno

211

Composizione
Composition





Un angolo ben definito. Il colore arreda con semplicità

A well defined corner.
The color furnishes with simplicity.

La composizione
può avere un grande
sviluppo anche in una
soluzione compatta,
con lunghe mensole
e tanti vani a giorno.

The composition
can have a big
development in a
compact solution,
with long shelves and
many open elements.

211

Composizione
Composition



Madreperla Ruggine Verde laguna

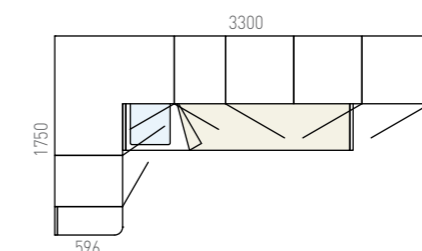

212

Composizione
Composition





Un pratico elemento con ripiani tra il letto e la scrivania

A practical storage unit with shelves between the bed and the desk

Aprendolo in alto si accede ad un comodo vano per cuscini o coperte, mentre di fianco si possono appoggiare giocattoli o libri.

Opening upward you access to a useful storage for pillows or blankets, while on the side is possible place toys or books.

* Elemento contenitore

Storage element

Vano a giorno con ripiano su entrambi i lati del contenitore
Open element with shelf on both sides of the box



Finiture disponibili: nobilitati bianco / madreperla / olmo bianco / canapa / urbano / monteago e tutti i colori laccati opachi e lucidi
Available finishes: melamine bianco / madreperla / olmo bianco / canapa / urbano / monteago and all the matt and gloss lacquered colors

212

Composizione
Composition

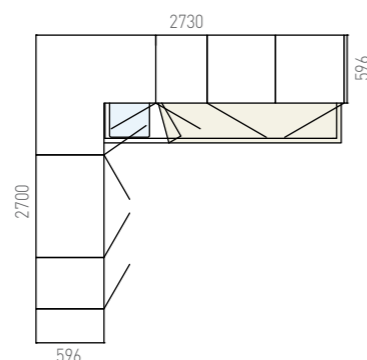
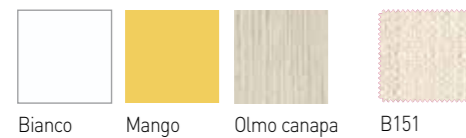

213

Composizione
Composition



Tre zone distinte, ma perfettamente coordinate: il letto sovrapposto con letto sottostante, la libreria con scrivania e l'armadio scorrevole.

Three distinct areas, but perfectly coordinated: the overlapping bed with bed below, the library with desk and sliding wardrobe.

*** Anta Centrale**
Door "Centrale"

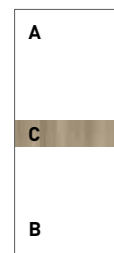

L 90 / 120,2 x H 230,6 / 243,4 / 262,6 cm

Finit. pannello A - B
Laccati standard
Laccati opachi
Laccati poro aperto

Inserto C
Nobilitati
Nobilitati "Elite"
Laccati standard
Laccati opachi
Laccati poro aperto

Finiture profili
Finitura Alluminio
Nobilitati
Laccati standard
Laccati opachi

*** Anta Joint**
Door "Joint"



Finishes panel A - B
Lacquered standard
Matt lacquered
Lacquered open pore

Insert C
Melamine
Melamine "Elite"
Lacquered standard
Matt lacquered
Lacquered open pore

Finishes profiles
Aluminium
Melamine
Lacquered standard
Matt lacquered



Ante scorrevoli:
mod. Centrale

Esempi di composizione
Composition examples

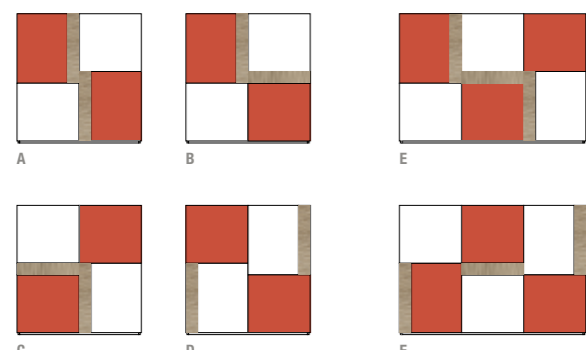

213

Composizione
Composition

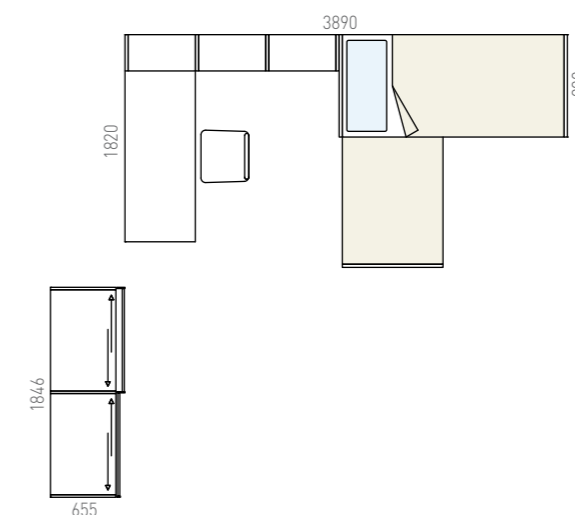
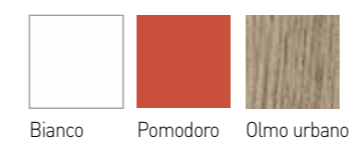

62

—
Feeling free to live the room without limits for studying, playing and sleeping.

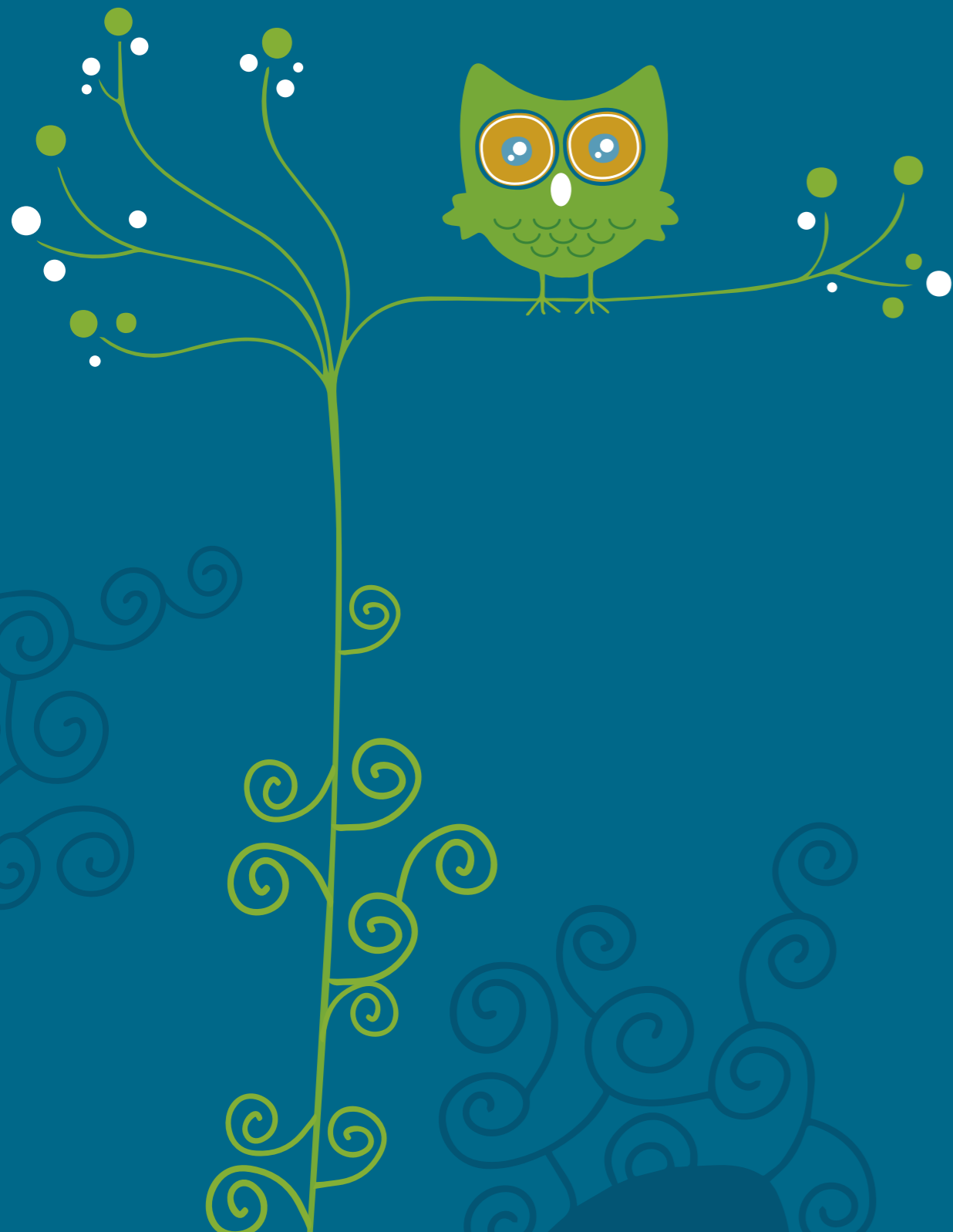

SENTIRSI
LIBERI DI
VIVERE
LA CAMERA
SENZA
LIMITI
PER
STUDIARE,
GIOCARÉ
E DORMIRE



214

Composizione
Composition



È una zona studio con scrivania e tanti ripiani per fare i compiti e avere sempre tutto vicino, in perfetto ordine.

It is a study area with desk and many shelves to do homeworks and having everything near, in perfect order.



I gradini per salire a letto sono dei pratici contenitori: dei volumi in più per organizzare la camera.

The steps to climb bed are practical containers: more volume to organize the room.

214

Composizione
Composition

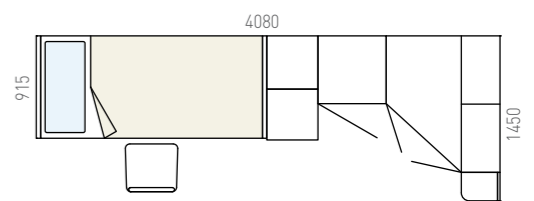



Di giorno il letto scorrevole rimane compatto per poter utilizzare librerie e scrittoio.

By day, the sliding bed is compact to use libraries and desk.

Di notte si sposta per poter salire comodamente.

At night it moves to be able to climb comfortably.

La protezione dà più sicurezza e praticità

The protection gives more safety and convenience

Con un semplice movimento, la protezione si abbassa per riassetare il letto in tutta comodità.

With a simple movement, you can lower the protection to rearrange the bed in comfort.

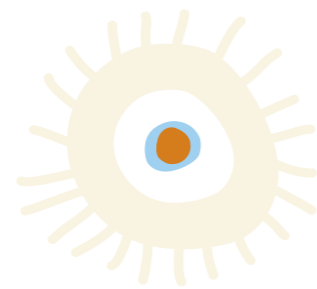



215

Composizione
Composition



Una camera naturale con la luminosità del bianco e la freschezza del bambù

A natural room with the brightness of the white and the freshness of bamboo

Spazi ampi, come la cabina che valorizza l'angolo, e atmosfere serene: in camera si sta sempre bene, con il colore e la semplicità.

Large spaces, such as the wardrobe that enhances the cabin, and peaceful atmospheres: in the room you feel always right, with the colors and the simplicity.

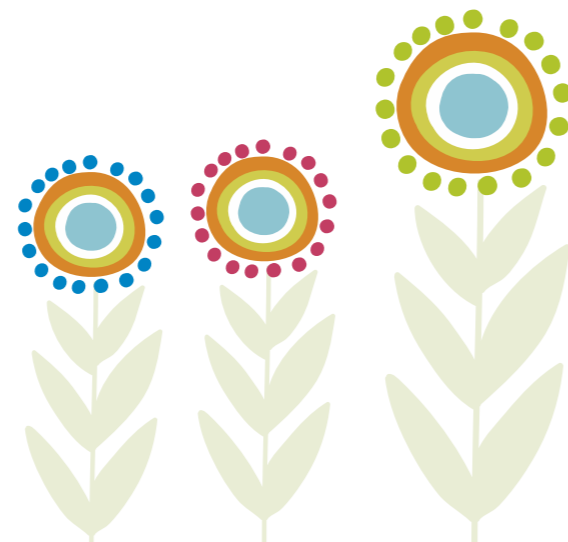



Lo spazio diventa un concetto flessibile con un arredo dinamico che si adatta alle esigenze del giorno e della notte.

Space becomes a flexible concept with a dynamic furniture that fits the needs of the day and night.

215

Composizione
Composition

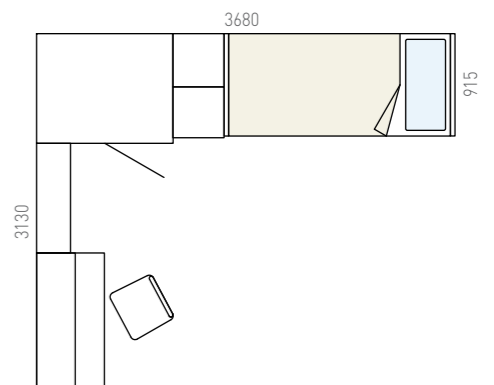
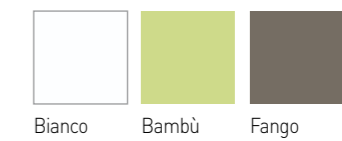

216

Composizione
Composition





Solo vani a giorno per dar spazio ad una comoda libreria.

Only open shelves to elarge space in a comfortable library.

Alla libreria a giorno si può affiancare la colonna chiusa con anta.

At the bookcase you can combine the column with closed door.

Il fianco dell'armadio da personalizzare come vuoi tu

The side of the cabinet to customize as you wish

Anche il fianco della cabina armadio può essere personalizzato combinando contenitore, vani a giorno e ripiani.

Even the side of the wardrobe can be customized combining elements, open spaces and shelves.



Meccanismo a ribalta

Folding mechanism

Massima praticità nel rifare il letto.

Maxim convenience in making the bed.



La cabina con fianco che diventa libreria

MIX Nuove forme per il fianco sagomato

Le nuove protezioni reclinabili

Scegli il tuo decoro preferito e crea il tuo letto, anche con il nuovo pannello di protezione.

Choose your favorite decoration and create your own bed, even with the new protection panel.

Laccato in
48 colori opachi



I fianchi sono disponibili in diverse forme, combinabili tra loro in base al gusto e alle esigenze per creare infinite possibilità.

The sides are available in different shapes, combined with each other according to the taste and needs to create endless possibilities.

Programma fianchi MIX



Fianco **A** Fianco **B** Fianco **C** Fianco **E** Fianco **metallo**

Finiture disponibili: nobilitati bianco / madreperla / olmo bianco / canapa / urbano / montego e tutti i colori laccati opachi
Available finishes: melamine bianco / madreperla / olmo bianco / canapa / urbano / montego and all the matt lacquered colors

216

Composizione
Composition

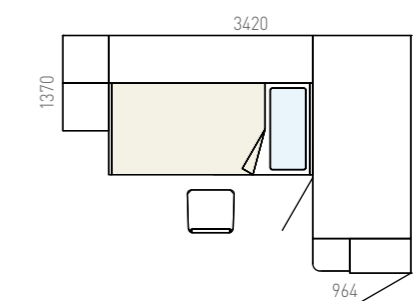
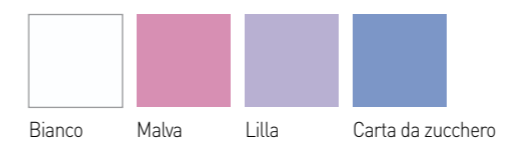

217

Composizione
Composition





Con le scale o la scaletta andare a letto è sempre divertente

With the ladder or small ladder is always fun to go to bed

Per accedere al letto più alto si possono scegliere due opzioni, valutando lo spazio a disposizione e il gusto personale.

To access the bed Highest you can choose from two options, evaluating the available space and personal taste.

217

Composizione
Composition

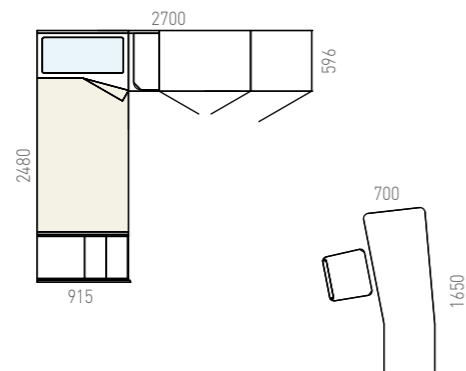
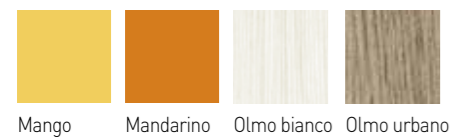

Con i pensili esagonali componi le tue mensole

218

Composizione
Composition





GLOBO Un'idea brillante: la luce è parte integrante dell'arredo

GLOBO
A brilliant idea: the light is an integral part

Ottimizzare gli spazi significa inventare nuove soluzioni: come le mensole vicino al letto superiore e le luci integrate per illuminare il letto e lo scrittoio.

Optimize space means inventing new solutions such as shelves near the upper bed and integrated lights to illuminate the bed and the desk.



La maniglia disco dello stesso colore dell'anta



Di notte si sposta il letto superiore per salire le scale.

At night you move the upper bed to climb the ladder.

Di giorno si crea un ampio spazio per la zona studio.

During the day, you create a large space for the study area.

Le posizioni cambiano per scoprire le scale e posizionare il letto e lo scrittoio dove è più comodo

The positions change to discover the stairs and place the bed and the desk where it is most convenient

La scrivania sotto il letto: possibile e pratica con la luce integrata e il fianco sagomato.

The desk under the bed: practical with the built-in light and the shaped side.

Fai scorrere il letto e sali sulla scaletta a gradini

218

Composizione
Composition

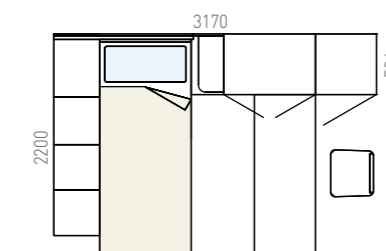
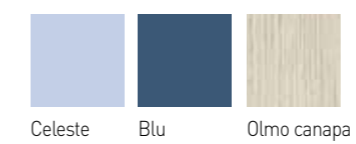



219

Composizione
Composition



Dormire più sicuri e protetti, con la protezione reclinabile



Come per magia esce il terzo letto estraibile per ospitare gli amici

Like magic out the third bed to accommodate friends

Se qualcuno vuole fermarsi a dormire non c'è da pensarci su: il letto per gli ospiti è già lì, estraibile con un semplice movimento.

If someone wants spend the night not think about it: the guest bed is already there, removable with a simple movement.

219

Composizione
Composition

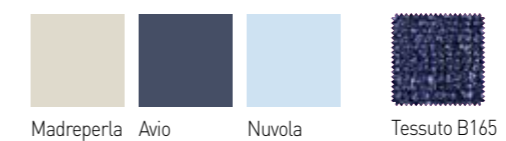

Madreperla Avio Nuvola Tessuto B165

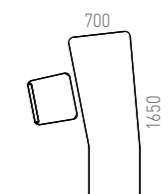
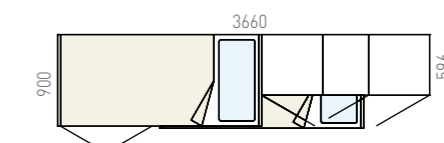



GLOBO La scrivania si rinnova per essere ancora più bella e pratica

The desk is renewed to be even more beautiful and practical

Lo scrittoio è ricco di novità: il nuovo piano sagomato e la gamba estensibile abbinati ai pensili esagonali creano un angolo studio completo.

The writing desk is full of novelty: the new shaped top and stretch leg combined with exagonal hanging create a complete study area.



Protezione reclinabile in metallo

Metal reclinable protection

Protezione reclinabile con sistema anti-sganciamento per la sicurezza del tuo bambino.

Reclinable Protection with anti-decoupling for the safety of your child.



La maniglia
incassata
tono su tono

220

Composizione
Composition

GLOBO
Ad ognuno il suo spazio, sviluppando la camera su due piani

GLOBO
To each one its own space,
developing the room on two floors

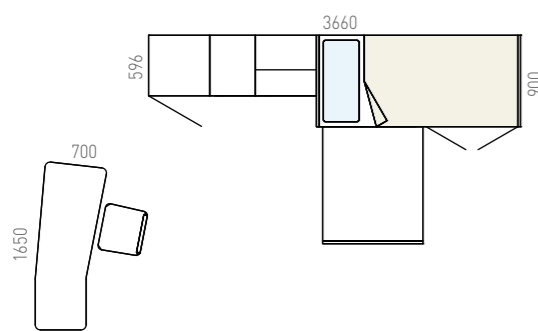



221

Composizione
Composition

Ponte con ante scorrevoli
facili da aprire



**Colonna multifunzionale:
ottimizza gli spazi
creando nuove
funzionalità per ogni
elemento**

Multifunctional column: optimizes space
creating new functionality for each element

Lo spazio non è mai
abbastanza e c'è
sempre qualcosa
da mettere in ordine.
Il fianco del ponte
attrezzato a libreria
è disponibile in
due altezze.

The space is never
enough and there is
always something
to put in order.
The side of the bridge
is equipped like library
and it is available in
two heights.

COLONNA MULTIFUNZIONALE

Multifunctional column

Finiture disponibili: nobilitati bianco / madreperla / olmo bianco /
canapa / urbano / montego e tutti i colori laccati opachi e lucidi
Available finishes: melamine bianco / madreperla / olmo bianco /
canapa / urbano / montego and all the matt and gloss lacquered colors

221

Composizione
Composition

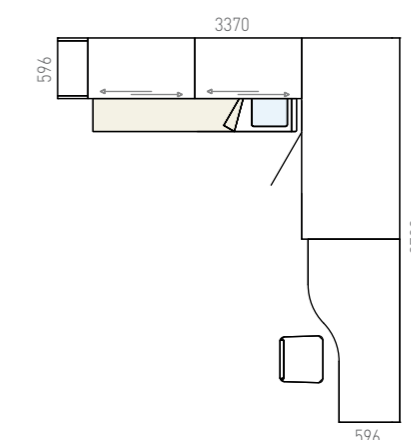
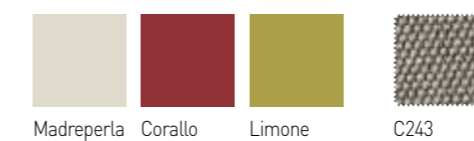



La cabina armadio: il guardaroba funzionale e capiente per tutte le stagioni

Una vera stanza nella stanza. La versatilità della collezione permette di realizzare composizioni abbinando armadi, librerie e letti a soppalco per dare alla cabina la giusta conformazione.

A real room within the room. The versatility of the collection allows you to create compositions combining wardrobes, bookcases and loft beds giving to the walk-in closet the right form.



A

Cabina rettangolare ad un'anta battente, abbinata con armadio Globo e letto a soppalco con scaletta in metallo

Rectangular walk-in closet with hinged door, combined with Globo wardrobe and loft bed with metal ladder

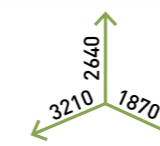

B

Cabina rettangolare ad un'anta battente, abbinata con librerie a giorno Globo e letto a soppalco con scaletta in metallo

Rectangular walk-in closet with hinged door, combined with Globo bookcases and loft bed with metal ladder



C

Cabina rettangolare a due ante battenti, abbinata con librerie a giorno Globo e letto a soppalco con scaletta in metallo

Rectangular walk-in closet with hinged doors, combined with Globo bookcases and loft bed with metal ladder

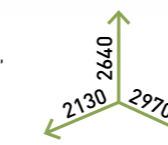

D

Cabina rettangolare ad un'anta battente, abbinata a librerie a giorno, terminale con mensole stondate e letto a soppalco con corridoio retro e scaletta laterale a tre gradini

Rectangular walk-in closet with hinged door, combined with bookcases, terminal element with rounded shelves and loft bed with back corridor and side ladder with three steps



222

Composizione
Composition



GLOBO Più spazio per lo studio Più comodità per la notte

More space for the study
More comfort for the night

È come avere più camere
in un solo ambiente:
i letti entrano nel ponte
per fare spazio allo
scrittoio e poi tornano al
loro posto quando è ora
di andare a dormire.

It's like having more
rooms in a single room:
the beds go inside the
bridge to make space
for the desk and then
exit to their place when
it's time going to sleep.





I binari sulla boiserie e le ruote sotto la pediera consentono un movimento leggero e fluido.

The tracks on the boiserie and the wheels under the footboard allow movement light and fluid.



Meccanismi sicuri con sistemi di bloccaggio

Secure mechanisms with locking systems

222

Composizione
Composition

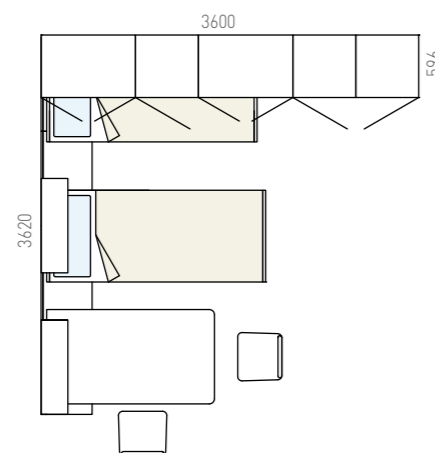
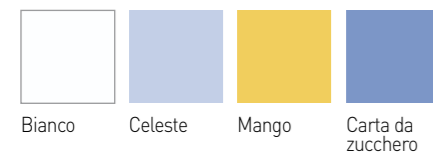

Al letto superiore si accede mediante una comoda scaletta agganciata alla pediera: due passi e si è subito a letto, protetti dalle protezioni in metallo.

The upper bed is accessed a convenient ladder attached to the footboard, two steps and you are in bed, protected by metal protections.



223

Composizione
Composition

GLOBO
Una camera
completa
in una sola
parete

A complete room in only one wall

Il progetto integra
Tutte le funzioni
In un'unica struttura,
con i colori che si
armonizzano dal bianco
alle sfumature del rosa.

The project integrates
All functions
In a single structure,
with colors that
harmonize from white
to shades of pink.





La struttura a ponte unisce il capiente armadio con due ante scorrevoli Twin, un settimanale, le mensole e uno scrittoio illuminato dai faretti Sunny e servito da una cassetiera su ruote come la sedia.

The bridge structure combines large closet with two sliding doors Twin, a dresser, shelves and a desk illuminated by spotlights Sunny and served by a drawers on wheels and by a chair.

223

Composizione
Composition

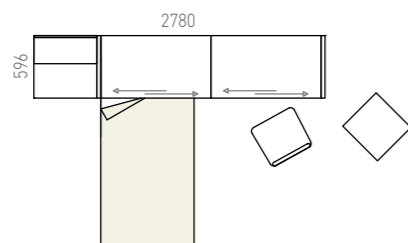
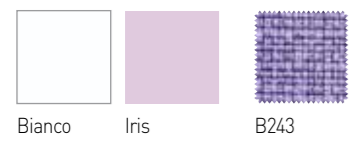

Il letto imbottito con ruote si posiziona dove è più comodo.

The upholstered bed with wheels is positioned where it is most convenient.

Ante scorrevoli
Twin: la fantasia
è in movimento!





224

Composizione
Composition



Arredare con allegria, praticità, convenienza. Dare alla camera dei ragazzi l'impronta del loro entusiasmo, della loro voglia di crescere e diventare grandi.

Cheerful, practical, low-cost furniture. In the kids' room express their enthusiasm, their desire to grow up and become adults.

224

Composizione
Composition

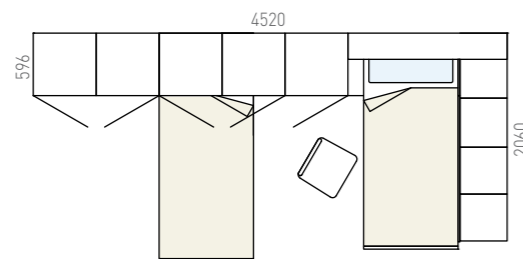
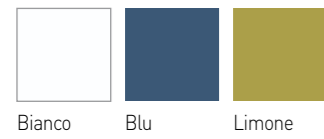

Il letto scorre e compaiono i gradini contenitore



225

Composizione
Composition



Il cassettone è ideale per cuscini, biancheria e giochi. The big drawer is ideal for pillows, linens and games.



La cassettera su ruote si posiziona dove vuoi tu. The drawer on wheels is positioned where you want it.

Strutture multiple per spazi intelligenti

Multiple structures for smart spaces

Il ponte e il letto sovrapposto con fianchi in metallo danno più luce e più comfort. Il grande scrittoio sagomato è ottimo per due brillanti studenti.

The bridge and the overlying bed with metal sides give more light and more comfort. The big desk shaped is great for two brilliant students.

225

Composizione
Composition

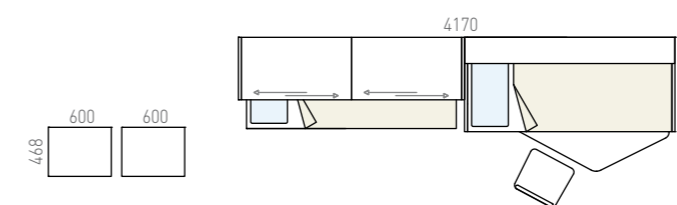
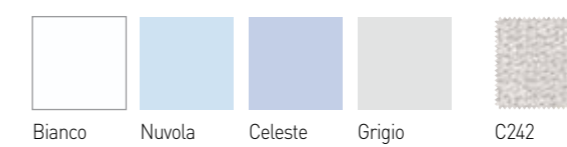

226

Composizione
Composition

Una spaziosa composizione a "U"

A spacious composition "U"

I fianchi in metallo creano strutture aperte e luminose, con uno scrittoio o un apposito letto alla turca sotto il ponte ad angolo.

The metal sides create open and bright structures, with a desk or a daybed, the corner bridge wardrobe.

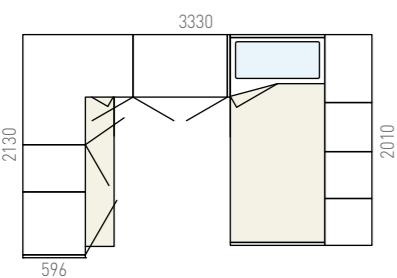
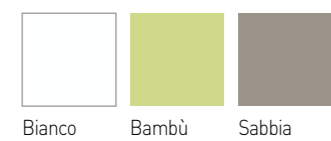

227

Composizione
Composition





Armadio a ponte con due ante scorrevoli e fianco in metallo. Bridge wardrobe with two sliding doors and metal side.

La scaletta appare come per magia

The ladder looks like magic

È una camera piena d'idee con il letto sovrapposto scorrevole e tanto spazio per il secondo letto, lo scrittoio e i vani a giorno.

It's a room full of ideas with sliding loft bed lot of space for the second bed, for desks and the open spaces.

227

Composizione
Composition

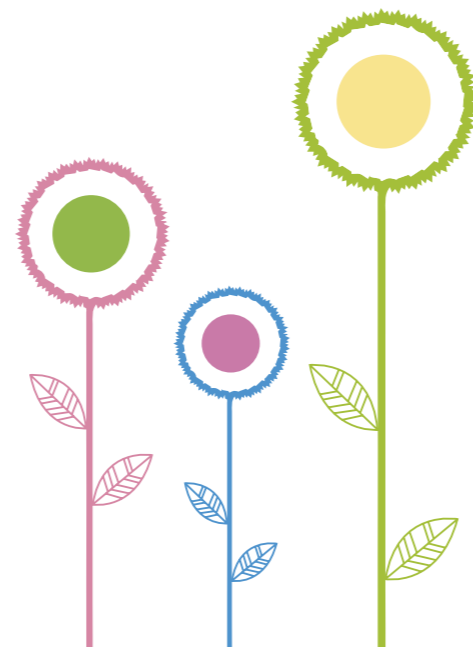
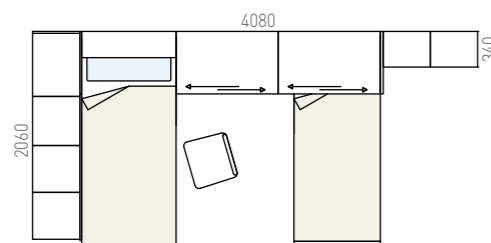
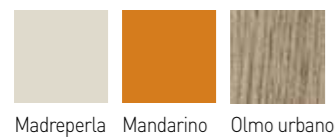

228

Composizione
Composition

Le soluzioni integrate che rendono tutto più semplice

The integrated solutions that make it easier

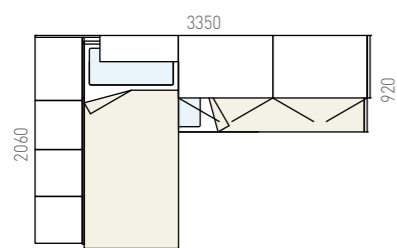
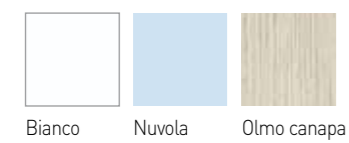

229

Composizione
Composition

**Un look colorato
per esprimere
tutta la vivacità
della camera**

A colorful look to showcase the
liveliness of room





Il letto con lo scrittoio estraibile

The bed with extractable desk

Ognuno ha il suo spazio per fare i compiti in piena tranquillità e per mettere in ordine, grazie alla libreria Vega con scrittoio integrato.

Everyone has their own space to do their homework in peace and quiet and to put in order, thanks to the library Vega with integrated desk.

229

Composizione
Composition

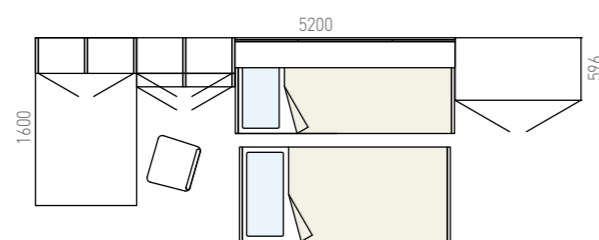

136

collection

PENSILI

—
The bookcase modules
are a useful and
colourful way of
equipping the wall by
exploiting the area with
versatile containers.

I PENSILI
SONO DEGLI
ELEMENTI UTILI
E COLORATI PER
ATTREZZARE
LA PARETE
SFRUTTANDONE
LA SUPERFICIE
CON DEI
VERSATILI
CONTENITORI

pensili TETRIS

struttura sp. 1,2 cm

Una forma geometricamente originale e una concezione che spinge al gioco e al libero posizionamento: Tetris è il pensile dinamico che dà un nuovo slancio alla libreria.

A geometrically original shape and a conception that pushes to the game and the free placement: Tetris is the dynamic wall unit that gives a new impetus to the library.

Finiture disponibili: in tutti i colori laccati opachi, lucidi e metal
Only available in matt, gloss and metal lacquered as color



Tetris abbinabile ai pensili 1.2 - Tetris with wall units 1.2

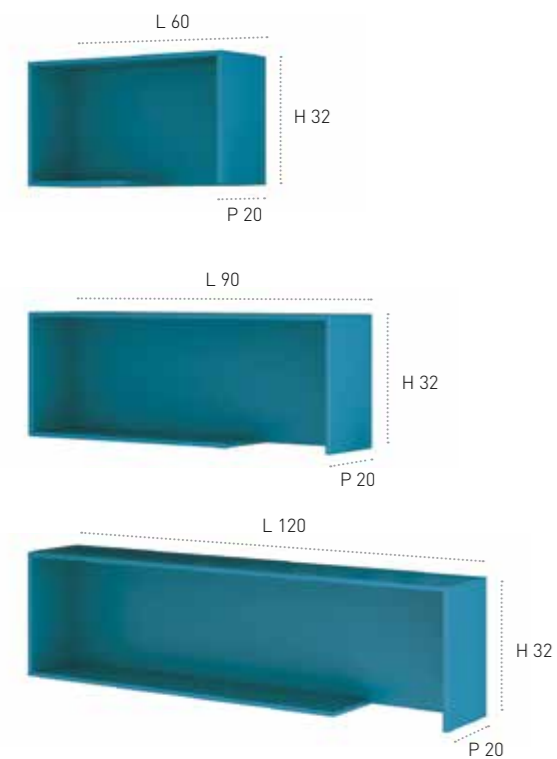

Esempi di componibilità - Modular examples

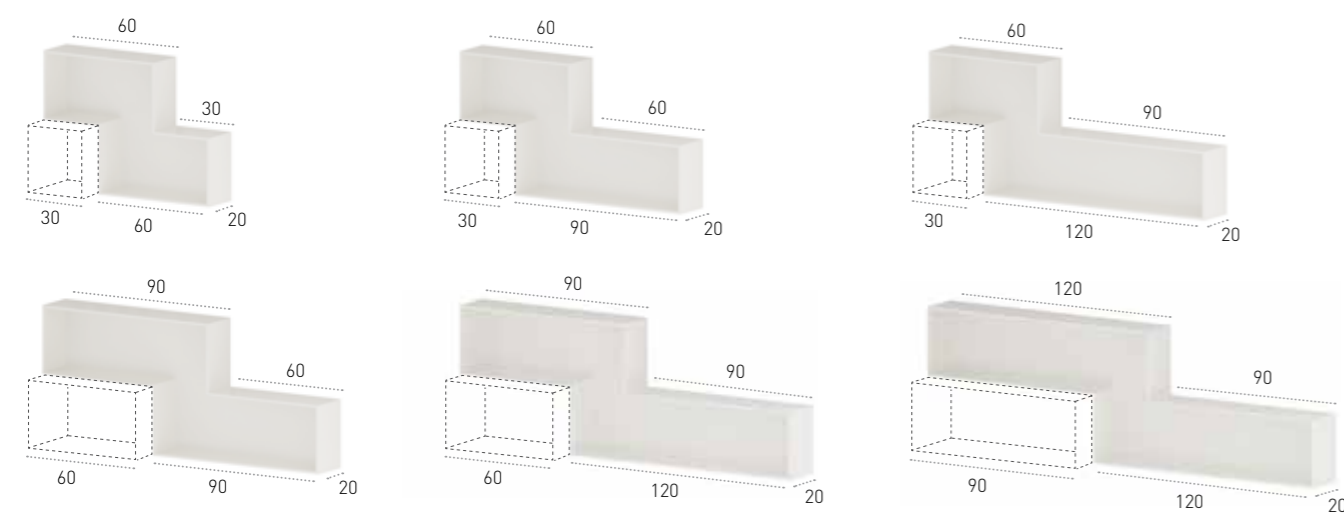

pensili ESAGONO

struttura sp. 1,2 cm

E' un'idea modulare estremamente versatile. Si creano composizioni personalizzate, mescolando i colori della collezione per completare la funzionalità dello scrivitorio o per avere, dove serve, delle mensole con o senza fianco di protezione, spesse 12 mm, belle da vedere e comode da usare.

It is an idea extremely versatile and modular. You create custom compositions, mixing colors of the collection to complete the functionality of the desk or to have, where it is needed, shelves with or without side protection, 12 mm thick, beautiful to look at and comfortable to use.

Finiture disponibili: in tutti i colori laccati opachi
Only available in matt lacquered as color

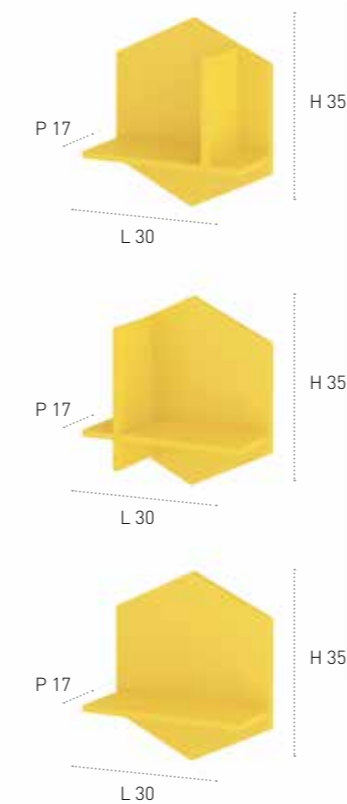
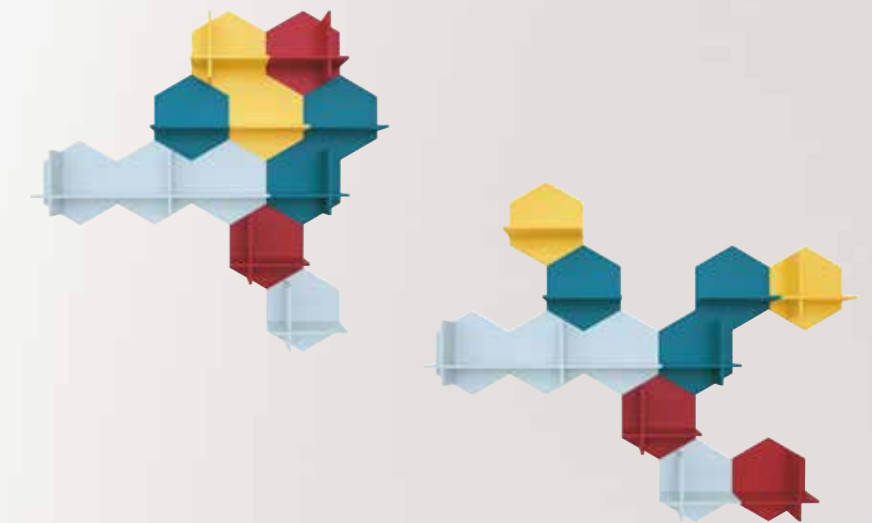

pensili KUBIK

struttura sp. 1,2 cm

Kubik è un complemento modulare molto pratico: i divisori interni lo rendono utilizzabile come libreria ma anche come porta oggetti, CD e DVD in composizioni libere.

Kubik is a very practical complement: the internal dividers make it usable as a library as well as holder of objects, CDs and DVDs in free compositions.

Finiture disponibili: in tutti i colori laccati opachi, lucidi e metal
Only available in matt, gloss and metal lacquered as color

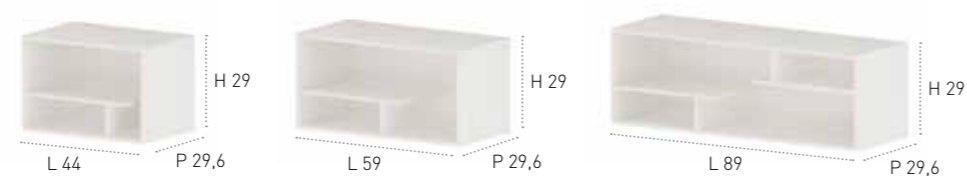

pensili KUBIK 2

struttura sp. 1,2 cm

Moduli da posizionare in orizzontale o in verticale, aperti alle estremità e con divisori interni, per creare librerie dinamiche, autonome o integrate alla composizione.

Modules to be placed horizontally or vertically, open at both ends and with internal dividers to create dynamic libraries, stand-alone or integrated to the composition.

Posizionabili in orizzontale o in verticale
They can be positioned horizontally or vertically

Finiture disponibili: in tutti i colori laccati opachi, lucidi e metal
Only available in matt, gloss and metal lacquered as color

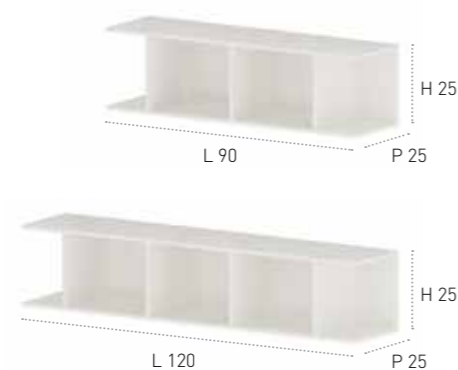

pensili PENSILI 1.2

struttura sp. 1,2 cm

Una linea di pensili a giorno con o senza ante da posizionare liberamente sulla parete sfruttando la grande modularità per creare composizioni versatili e multifunzionali.

A range of wall units with or without a door to be placed freely on the wall taking advantage of the high modularity to create versatile and multifunctional compositions.

Struttura disponibile nelle finiture nobilitato bianco, madreperla, olmo bianco, canapa, urbano, monteago, laccato opaco, laccato lucido e metal. Ante disponibili nelle versioni light, laccato poro aperto, lux e metal.
Structure available in bianco melamine finish, madreperla, olmo bianco, canapa, urbano, monteago matt lacquered, glossy lacquered and metal. Doors available in light, open pore lacquered, metal and lux.

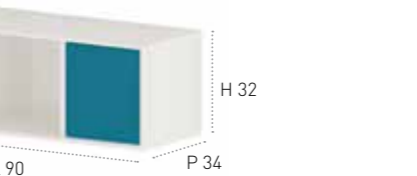
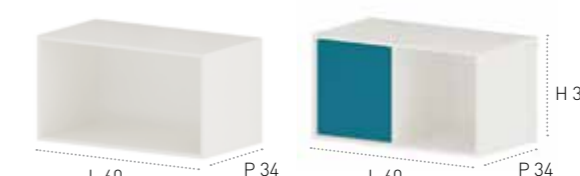
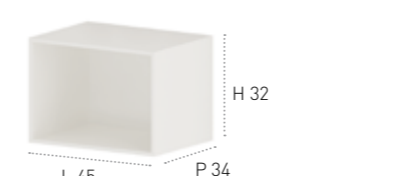
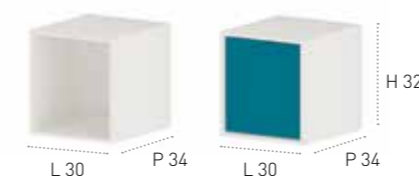

142

letti

ESSENZA COLORE

Spagnol collection
expresses the pleasure
of form, value comfort
and a look that is
always fresh and young
with the cozy warmth
of wood essence and
the cheerful and
vivid colors.

LA COLLEZIONE
SPAGNOL
ESPRIME LA
PIACEVOLEZZA
DELLA FORMA,
IL VALORE
COMFORT E UN
LOOK SEMPRE
FRESCO E
GIOVANE CON
L'ACCOGLIENTE
CALORE
DELL'ESSENZA
E L'ALLEGRA
VIVACITÀ DEI
COLORI

letti ESSENZA/COLORE

L'olmo in quattro tonalità più il bianco e il madreperla: essenze moderne ideali per la camera dei ragazzi. Il colore laccato opaco in 48 tinte: si spazia da quelle più di tendenza a quelle classiche, da quelle più vivaci a quelle neutre. La scelta tra i diversi tipi di Ring, esprime liberamente il proprio stile.

The elm in four colors plus white colour and mother of pearl: modern essences ideal for children's bedrooms. The matt lacquered color in 48 tints: ranging from the most trendy to classic, from the most vibrant to neutral ones. The choice between the different types of bed frames, expresses freely his own style.

6 finiture nobilitato / melamine finishes

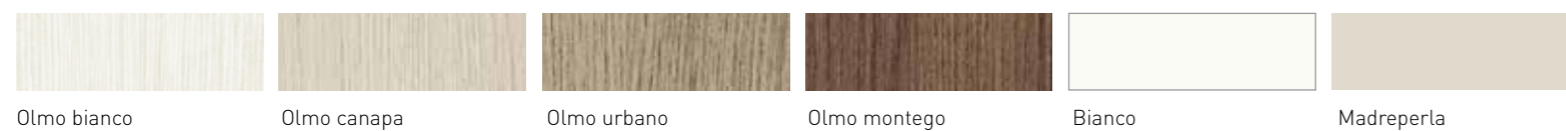

Olmo bianco Olmo canapa Olmo urbano Olmo montego Bianco Madreperla

48 laccati opachi / matt lacquered



Letto con ring R1
Bed with ring R1



Letto con ring R2
Bed with ring R2



Letto con ring R3
Bed with ring R3



Letto con pediera abbinata
Bed with footboard combined



LETTI

Beds

RING R1



Rete da 82/92 - 122/162

RING R2



Rete da 82/92 - 122/162

RING R2 c/contenitore



Rete da 82/92 - 122/162

RING R3



Rete da 82/92 - 122/162



Letto **ANTARES** con **pediera abbinata**
Disponibile anche con RING R1 - R2



Letto **ARI** con **RING R1**
Disponibile solo con rete L 82/92
anche con RING R2 - R2 CONT - R3



Letto **CAT** con **pediera abbinata** [solo rete 82-92]
Disponibile anche con RING R1 - R2 - R2 CONT
pediera abbinata cont.



Letto **EROS** con **RING R3**
Disponibile solo con rete L 92



Letto **BLOOM** con **RING R1**
Disponibile anche con R2 - R2 CONT
e **pediera abbinata**



Letto **BOOK** con **RING R3**
Disponibile solo con rete L 82



Letto **FLOCK** con **RING R3**



Letto **FLY** con **pediera abbinata**
Disponibile solo con rete L 82-92
anche con RING R1 - R2 - R2 CONT
pediera abbinata cont.



Letto **BRIO** con **RING R3**



Letto **CARD** con **RING R3**
Disponibile solo con rete L 82



Letto **GATE** con **RING R3**



Letto **SIRIO** con **pediera abbinata**
Disponibile anche con RING R1 - R2

LETTI

Beds

RING R1



Rete da 82/92 - 122/162

RING R2



Rete da 82/92 - 122/162

RING R2 c/contenitore



Rete da 82/92 - 122/162

RING R3



Rete da 82/92 - 122/162



Letto **STAR** con **pediera abbinata**
Disponibile solo con rete L 82-122-162
anche con RING R1 - R2



Letto **MELA** con **RING R3**
Disponibile solo con rete L 82



Letto **MIX** con **pediera abbinata**
Disponibile solo con rete L 82-92
anche con RING R1 - R2 - R2 CONT
pediera abbinata cont.



Letto **TENDER** con **RING R2**
Disponibile anche con RING R1 - R2 CONT - R3



Letto **TEO** con **RING R1**
Disponibile solo con rete L 82-92
anche con RING R2 - R2 CONT - **pediera abbinata**
pediera abbinata cont.



Letto **PRETTY** con **RING R3**



Letto **SLIM** con **RING R1**
Disponibile anche con RING R2 - R2 CONT
pediera abbinata - pediera abbinata cont.



Letto **TEX** con **RING R2**
Disponibile solo con rete L 82-92
anche con RING R2 CONT - R3



Letto **TWIT** con **RING R3**



Letto **SOL** con **RING R2** [solo rete 82-92]
Disponibile anche con R2 CONT - R3



Letto **SONG** con **RING R2**
Disponibile anche con RING R1 - R2 CONT - R3



Letto **UP** con **pediera abbinata**
Disponibile solo con rete L 82-92-122
anche con RING R1 - R2 - R2 CONT - R3
pediera abbinata cont.



Letto **ZEN** con **pediera abbinata**
Disponibile solo con rete L 92-122
anche con RING R1 - R2 - R2 CONT
pediera abbinata cont.

TURCHE

Independent bed

RETE DA 82 / 92 cm
SLATTED BASE FROM 82/92 cm



Turca **BLOOM**
Disponibile anche con rete estraibile per materasso H 20 cm



Turca **CAT**



Turca **FLY**



Turca **MIX**



Turca **SLIM**
Disponibile anche con rete estraibile per materasso H 20 cm



Turca **STAR** (disponibile solo con rete L 82)



Turca **TEO**



Turca **SIRIO**



Turca **UP**



Turca **ZEN**

DIVANI LETTO

Beds sofa

RETE DA 82 cm
SLATTED BASE FROM 82 cm



Divano Letto **FLY**



Divano Letto **MIX**



Divano Letto **SLIM**



Divano Letto **UP**

ESTRAIBILI SOTTO LETTO

Extractable



Letto estraibile
Extractable bed



Coppia cassetti estraibili con ruote
Couple of drawers with wheels

PROGRAMMA LETTI

Beds program

MODELLO UP LETTI RIALZATI

Raised beds



CON RUOTE / With wheels
SENZA RUOTE / Without wheels



CON RUOTE / With wheels
SENZA RUOTE / Without wheels



TURCA ESTRAIBILE CON RUOTE
Independent bed extractable with wheels

MODELLO FLY LETTI RIALZATI

Raised beds



CON RUOTE / With wheels
SENZA RUOTE / Without wheels



CON RUOTE / With wheels
SENZA RUOTE / Without wheels



TURCA ESTRAIBILE CON RUOTE
Independent bed extractable with wheels

LETTI SOVRAPPOSTI

Bunk beds

Esempio di combinazioni / Example of combinations



LETTI SOVRAPPOSTI

Bunk beds

Esempio di combinazioni / Example of combinations



FIANCHI UP PER LETTI SOVRAPPOSTI

Side up for bunk beds

I fianchi sono disponibili in diverse forme, combinabili tra loro in base al gusto e alle esigenze per creare infinite possibilità
The sides are available in different shapes, combined each other based on liking and needs to create endless possibilities

Nuovo fianco libreria
New side library



FIANCHI FLY PER LETTI SOVRAPPOSTI

Side fly for bunk beds

I fianchi sono disponibili in diverse forme, combinabili tra loro in base al gusto e alle esigenze per creare infinite possibilità
The sides are available in different shapes, combined each other based on liking and needs to create endless possibilities



PROGRAMMA LETTI

Beds program

MODELLO MIX

LETTI RIALZATI

Raised beds



CON RUOTE / With wheels
SENZA RUOTE / Without wheels



CON RUOTE / With wheels
SENZA RUOTE / Without wheels



TURCA ESTRAIBILE CON RUOTE
Independent bed extractable with wheels

LETTI SOVRAPPOSTI

Bunk beds

Esempio di combinazioni / Example of combinations



FIANCHI MIX PER LETTI SOVRAPPOSTI

Side up for bunk beds

I fianchi sono disponibili in diverse forme, combinabili tra loro in base al gusto e alle esigenze per creare infinite possibilità
The sides are available in different shapes, combined each other based on liking and needs to create endless possibilities

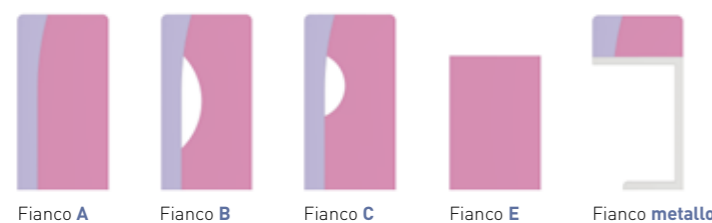

LETTI RIALZATI CON PROFILO BOMBATO IN METALLO

Raised beds with rounded profile metal



Letto rialzato art. LR0311R
Turca estraibile art. LR0313R
Coppia cassetti su ruote art. LS0020
Raised bed art. LR0311R
Independent bed extractable art. LR0313R
Couple of drawers on wheels art. LS0020



Letto rialzato art. LR0312R
Turca con quattro cassetti art. LR0314R
Raised bed art. LR0312R
Independent bed with four drawers art. LR0314R



Letto rialzato art. LR0310R
Turca con quattro cassetti art. LR0314R
Raised bed art. LR0310R
Independent bed with four drawers art. LR0314R



Letto rialzato art. LR0312R
Turca estraibile art. LR0313R
Rete estraibile art. LR0021D
Raised bed art. LR0312R
Turkish removable art. LR0312R
Network Removable art. LR0313R



letti IMBOTTITI

Il letto arreda, non solo per la forma, ma soprattutto per la scelta dei rivestimenti. La collezione dei tessuti mette a disposizione la fantasia dei decori con una vasta gamma a vostra scelta. La forza espressiva dei colori e la sensazione dei materiali per trasformare ogni letto in un oggetto di design unico e personale, in una camera ricca di stimoli e creatività.

The bed furnishes, not only for the shape, but especially for the choice of the coatings. The collection of fabrics provides the fancy decorations with a variety of choice. The expressive power of color and the feel of the materials to transform any bed into a unique and personal design, in a room full of stimulus and creativity.

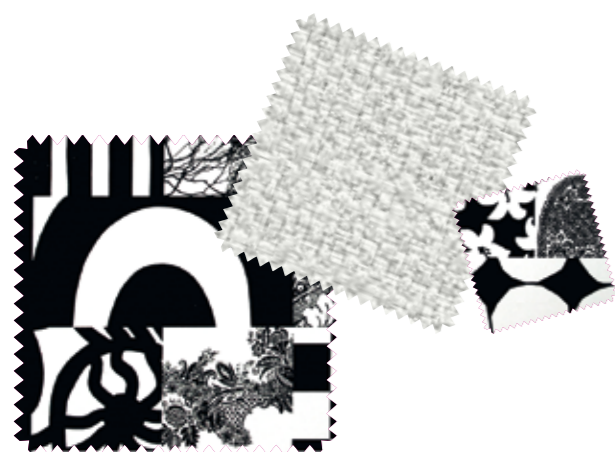

CREA IL TUO STILE CON OLTRE 300 TESSUTI

Scegli sul campionario le infinite possibilità di fantasie e colori in tessuto o in ecopelle.

Choose on the sample the endless possibilities of patterns and colors in fabric or leather.

LETTI IMBOTTITI "SFODERABILI"

Upholstered beds "removable"

RETE DA 80 / 90 / 120 / 160 cm
SLATTED BASE FROM 80 / 90 / 120 / 160 cm

RING Ri1



RING Ri2



RING Ri3



RING Ri4



RING Ri5



RING Ri6



Letto **DESI** con RING Ri6



Letto **LUXOR** con RING Ri5
Disponibile anche con RING Ri1 - Ri2 - Ri3



Letto **LOVE ME** con RING Ri3
Disponibile anche con RING Ri1 - Ri2



Letto **STEP** con RING Ri4
Disponibile anche con RING Ri1 - Ri2



Letto **VERTIGO** con RING Ri4
Disponibile anche con RING Ri1 - Ri2

PROGRAMMA LETTI IMBOTTITI "SFODERABILI"

Program upholstered beds "removable"

MODELLO EASY

RETE DA 80 cm
SLATTED BASE FROM 80 cm



Letto singolo
Single bed



Predisposizione 2° letto
2nd bed arrangement



Predisposizione cassetti
Drawers arrangement

MODELLO EOLO

RETE DA 80/120 cm
SLATTED BASE FROM 80/120 cm



Letto singolo
Single bed



Predisposizione 2° letto
2nd bed arrangement



Predisposizione cassetti
Drawers arrangement



Letto contenitore
Open holder

MODELLO PISOLO

RETE DA 120 cm
SLATTED BASE FROM 120 cm



Letto
Bed



Predisposizione 2° letto
2nd bed arrangement



Predisposizione cassetti
Drawers arrangement



Letto con materasso da 90 e panca
Bed with mattress 90 and bench



Letto contenitore con materasso da 90 e panca
Bed with holder mattress 90 and bench



Letto contenitore
Open holder

DIVANI LETTO IMBOTTITI "SFODERABILI"

Upholstered sofa beds "removable"

RETE DA 80 cm
SLATTED BASE FROM 80 cm

MODELLO EASY



Divano letto
Upholstered sofa beds



Predisposizione 2° letto
2nd bed arrangement



Contenitore con ap. laterale
Holder with lateral opening



Divano letto
Upholstered sofa beds



Predisposizione cassetti
Drawers arrangement



Contenitore con ap. laterale
Holder with lateral opening

MODELLO EOLO



Divano letto
Upholstered sofa beds



Predisposizione 2° letto
2nd bed arrangement



Contenitore con ap. laterale
Holder with lateral opening



Divano letto
Upholstered sofa beds



Predisposizione 2° letto
2nd bed arrangement



Predisposizione cassetti
Drawers arrangement



Contenitore con ap. laterale
Holder with lateral opening

TURCHE IMBOTTITE "SFODERABILI"

Upholstered independent bed "removable"

RETE DA 80 / 90 / 120 / 160 cm
SLATTED BASE FROM 80 / 90 / 120 / 160 cm



Turca **OVER** con RING Ri1 - Ri2



Turca **SIDE** con RING Ri3



Turca **END** con RING Ri4

RETE DA 80 cm
SLATTED BASE FROM 80 cm



Turca **EASY**



Predisposizione 2° letto
2nd bed arrangement



Predisposizione cassetti
Drawers arrangement

POUF

Pouf



QUADRO
40x40



SOFTY
50x50



KUBICO
70x70



OBELIX
Ø 55



OBELIX
Ø 75



MAGIC trasformabile
70x76 (aperto 76x202)



POLTRONCINE

Armchairs



STYLO



SPACE



LULÙ



ALISON



DIVA

SEDIE

Chairs



JENNY
con gambe



JENNY
con ruote



JENNY imbottita
con gambe



JENNY imbottita
con ruote



SIRIO



QUADRO ASOLA



QUADRO ROTONDO



FIORE



CUORE



OLA

GAMBE PER PIANI SCRITTOI

Legs for writing desk

Una forma per ogni stile. Lo scrittoio è sempre personalizzato e si crea abbinando una delle molteplici sagomature del piano ad una delle tante tipologie di gambe della collezione.

A form for each style. The writing desk is always personalized with many shapes of the desk and with many types of legs of the collection.



Piano sospeso Jump
Jump hung top



Pannello sp. 3,8 / 5,8 cm
Panel sp. 3,8 / 5,8 cm



Cono su ruote
Cone on wheels



Cono
Cone



Cilindro
Cylinder



Corner
Corner



King
King



King su ruote
King on wheels



Cavalletto
Easel



Factor
Factor



Factor su ruote
Factor on wheels

164

collezione

ARMADI

It is not just an irreplaceable holder, but a perfectly organized and equipped volume that becomes a furniture component thanks to the design and the doors decoration. Both it has hinged or sliding door and it is walk-in, Spagnol wardrobe is always a surprise with its versatility.

NON È SOLO UN
CONTENITORE
INSOSTITUIBILE,
MA UN VOLUME
PERFETTAMENTE
ORGANIZZATO E
ATTREZZATO CHE
DIVENTA OGGETTO
D'ARREDO CON
IL DESIGN E LA
DECORAZIONE
DELLE ANTE.
CHE SIA BATTENTE,
SCORREVOLE O
CABINA, L'ARMADIO
SORPRENDE
SEMPRE PER LA
SUA VERSATILITÀ

ARMADI

BATTENTE E SCORREVOLE

Immaginalo con il sistema d'apertura che preferisci. Progetta con ripiani, cassetiere e accessori. Abbinare l'anta che preferisci e poi colorarla con la mazzetta Spagnol che spazia dalle tinte più innovative a quelle classiche, da quelle neutre a quelle vivaci, oppure vestilo con le calde venature di una delle quattro essenze della collezione e crea un armadio tutto per te.

Think to the opening system you prefer. Design it with shelves, drawers and accessories. Combine the door that you prefer and paint it with a color of the range of Spagnol collection, from the most innovative to the classic colors, from neutral to bright ones, or wear it with one of the warm four essences of the collection and creates yours wardrobe.

1 finitura nobilitato / melamine finishes



Per struttura interna armadio scorrevole e cassetiere interne
For internal sliding wardrobe structure and internal drawer unit

Bianco millerighe

6 finiture nobilitato / melamine finishes



Olmo bianco Olmo canapa Olmo urbano Olmo montego Bianco Madreperla

48 laccati opachi / matt lacquered



29 laccati lucidi / gloss lacquered



Struttura interna / esterna

6 finiture nobilitato / 48 colori opachi / 29 colori lucidi / 3 laccati opachi metallizzati

Structure Internal / External

6 melamine finishing / 48 matt colors / 29 glossy colors / 3 metal lacquers

Ante

16 finiture nobilitato / 48 colori opachi / 29 colori lucidi / 3 laccati opachi metallizzati

Door

16 melamine finishing / 48 colors matt / 29 colors glossy / 3 metal lacquers

Cassetiera interna

Bianco millerighe

Internal drawers
Bianco millerighe

3 laccati metal / metal lacquers



Perla metallizzato Gold metallizzato Titanio metallizzato

16 finiture nobilitato per frontali Spazio (ante battenti e cassetti) / melamine finishes for door Spazio (doors and drawers)

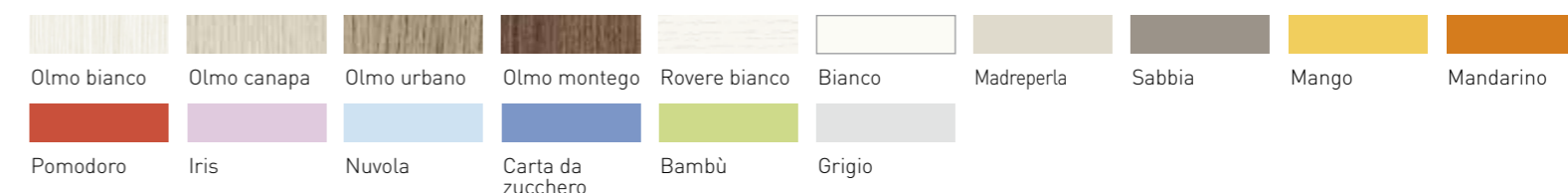

FRONTALI (ANTA BATTENTE E CASSETTO)

Front



FRONTALI / FRONT SPAZIO

Pannello nobilitato sp.18 mm con bordo ABS sp.1 mm su tutti i lati, in finitura Olmo bianco, canapa, urbano, montego, rovere bianco, bianco, madreperla, sabbia, mango, mandarino, pomodoro, bambù, iris, nuvola, carta da zucchero e grigio.

Melamine 18 mm thick with 1 mm thick ABS edging on all sides, finish white elm, hemp, urban, montego, white oak, white, pearl, sand, mango, tangerine, tomato, bamboo, irises, cloud, sugar paper and grey.



FRONTALI / FRONT LUX

Pannello nobilitato sp.18 mm con bordo ABS sp.1 mm su tutti i lati, finitura nei colori laccati lucidi.

Chipboard 18 mm with 1 mm thick ABS edging on all sides, finished in glossy lacquered colors.



FRONTALI / FRONT LIGHT

Pannello nobilitato sp.18 mm con bordo ABS sp.1 mm in tutti i lati, finitura nei colori laccati opachi con vernici all'acqua atossiche.

Chipboard 18 mm with 1 mm thick ABS edging on all sides, finished in matt colors with non-toxic water-based paints.



PERSONALIZZA LE ANTE DELL'ARMADIO CON LA TUA IMMAGINE PREFERITA

Ti proponiamo alcuni esempi di come il tuo armadio può diventare un quadro, riproducendo a tutta grandezza una tua foto o il disegno che vuoi. La serigrafia può essere fatta su ante (battenti e scorrevoli), fianchi, pannelli boiserie e pannelli al mq.

We offer you few examples of how your closet can be painted, reproduction your photo or design in big dimensions. Serigraphy can be done on doors (hinged or sliding), side panels, wall panels and panels per square meter.



FRONTALI / FRONT LACCATO PORO OPACO

Pannello nobilitato sp.18 mm in finitura poro aperto rovere con bordo ABS sp.1 mm su tutti i lati, finitura nei colori laccati opachi con vernici all'acqua atossiche.

Chipboard 18 mm in open pore dark oak finish with 1 mm thick ABS edging on all sides, finished in matt colors with non-toxic water-based paints.



FRONTALI / FRONT MOVIE

Pannello nobilitato sp. 18 mm con bordo ABS 1 mm nei 4 lati, laccato con vernici all'acqua goffrate opache atossiche, serigrafia a getto d'inchiostro.

Melamine sp. 18 mm with 1 mm ABS edge in the 4 sides, lacquered embossed matt with non toxic water-based paint, ink jet silkscreen.

Serigrafia Movie disponibile su ante, fianchi, pannelli boiserie e pannelli al mq

L'anta Light si trasforma in Movie con la serigrafia delle tue immagini preferite. E il look della camera non ha più limiti. **Queste sono alcune delle texture che noi proponiamo, ma si possono serigrafare anche le vostre immagini, per personalizzare la camera.**

The Light door turns into Movie with screen printing of your favorite pictures. And the look of the room has no more limits. These are some of the textures we propose, but you can also screen print your images, to personalize the room.

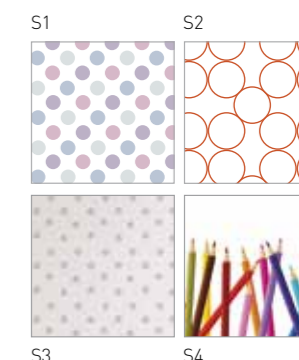

MANIGLIE E POMOLI

Handles and knobs

Le maniglie spaziano dalle forme essenziali a quelle decorative, dai colori alle diverse finiture per dare alle ante e ai frontali un tocco personale. Linee rette o curve, forme rotonde o quadrate per scelte tradizionali o creative, sempre a partire da una presa sicura e piacevole al tatto.

Handles ranges, from basic shapes to decorative from colors to different finishes to give the to door a personal touch. Straight or curved lines, round or square shapes for traditional or creative choices, always for a safe and pleasant grip.

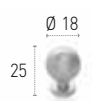

SFERA



Alluminio satinato
Brushed aluminum

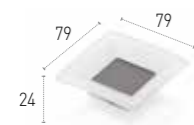

CUBE

Passo / Step 32 mm



Laccati opachi
Matt lacquered



FIORE



Laccati opachi
Matt lacquered



CLAP



Laccati opachi
Matt lacquered

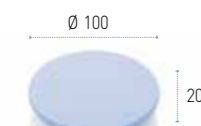

DISCO



Laccati opachi
Matt lacquered

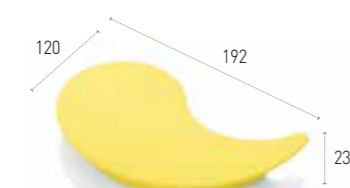

WAVE

Passo / Step 128 mm



Laccati opachi
Matt lacquered



ALLUMINIA

Passo / Step 160 mm
Passo / Step 896 mm



Bianco
White



Moka
Moka



Alluminio satinato
Brushed aluminum

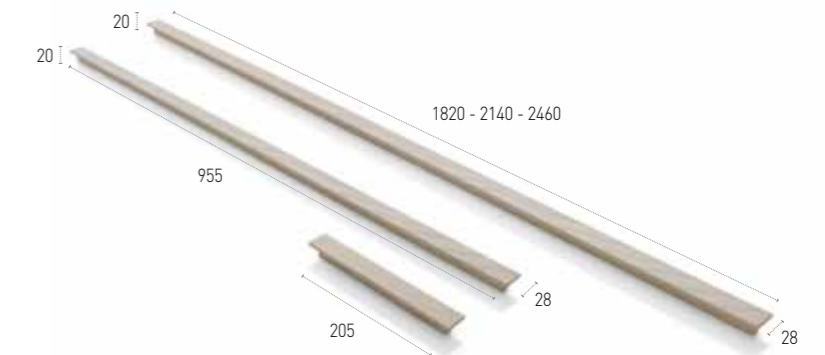

TASSELLO

Passo / Step 160 mm
Passo / Step 896 mm

OLMO



Bianco
White



Canapa
Canapa



Urbano
Urbano



Montego
Montego



Bianco
White



Laccati opachi
Matt lacquered

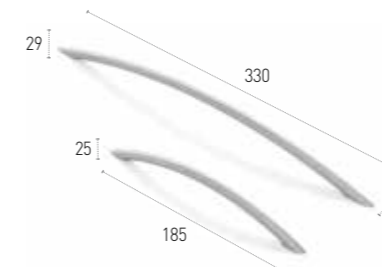

ARCHETTO

Passo / Step 160 mm
Passo / Step 288 mm



Bianco
White



Moka
Moka



Alluminio satinato
Brushed aluminum

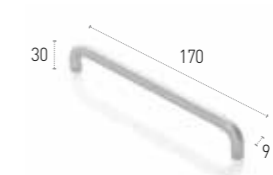

PONTE

Passo / Step 160 mm



Alluminio satinato
Brushed aluminum

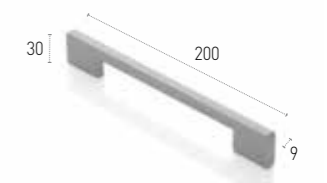

SATINATA

Passo / Step 160 mm



Laccati opachi
Matt lacquered

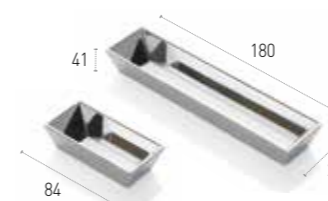

PIRAMIDE

Passo / Step 160 mm
Passo / Step 64 mm



Cromato
Chrome



Laccati opachi
Matt lacquered

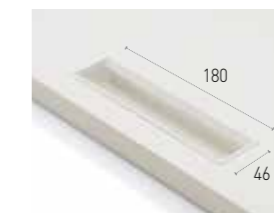

INCASSO



Bianco
White



Laccati opachi
Matt lacquered



PUSH-PULL



Alluminio satinato
Brushed aluminum



arreda con noi
la tua casa. furnish with us
your home.

SPAGNOLmobili SPAGNOLsalotti SPAGNOLcucine SPAGNOLcontract SPAGNOLmaterassi SPAGNOLleathersofa MOBILofficefurniture LAVALLEarredobagno VALPLANAcollections



SPAGNOLcucine

CUCINA

Un viaggio nelle forme della cucina, con gusto e funzionalità.

KITCHEN
A trip to the style of the kitchen, tastefully and functionality.



SPAGNOLmobili

LIVING

La versatilità e l'estetica dei sistemi a contenitore e a spalla portante.

LIVING
The versatility and aesthetics cabinets systems and side stand.



SPAGNOLsalotti SPAGNOLleathersofa

DIVANI

Il confort in oltre 200 varianti di colore di tessuto e morbida pelle.

SOFAS
The comfort in over 200 different colors of fabric and soft leather.



SPAGNOLmobili

CAMERE

Una grande scelta di armadi, cabine, letti e complementi per arredare liberamente.

BEDROOMS
A great choice of wardrobes, beds, and accessories to furnish freely.



SPAGNOLmobili

CAMERETTE

Infinite soluzioni di arredo moderne e contemporanee per bambini e ragazzi di tutte le età.

BEDROOMS
Unlimited solution of modern and contemporary furniture for children of any age.



MOBILofficefurniture

UFFICIO

L'arredo completo per l'ufficio e lo studio di casa.

OFFICE
The complete furnishings for the office and home office.



LAVALLEarredobagno

BAGNO

Stile, funzionalità, eleganza nei colori e nelle essenze naturali per vivere il tuo bagno nel massimo relax.

BATH
Style, functionality, elegance in the colors and natural woods to experience your bathroom in the maximum relax.



VALPLANAcollections

VALPLANA

Il profumo del legno nel rispetto della natura. Specializzata nella produzione di cucine, soggiorni, camere e bagni in stile country.

VALPLANA
The scent of wood in harmony with the nature. Specialized in the production of kitchens, living rooms, bedrooms and bathrooms in country style.

I NOSTRI VALORI

our values



SPAGNOLmobili

GARANZIA ESTENDIBILE A 10 ANNI

Spagnol Mobili offre la possibilità di estendere il periodo di garanzia sui propri prodotti da 2 a 10 anni dalla data di fabbricazione.

* Vedi condizioni specifiche nel certificato di garanzia.

EXTENDED WARRENTY ONLY FOR ITALY.
International Warrenty: 2 Years



VERNICI ALL'ACQUA ANTIBATTERICHE CON SILVER DEFENCE

Vengono utilizzate vernici all'acqua monocomponente prive di solventi chimici nocivi. Inoltre, grazie agli additivi Silver Defence, la laccatura diventa barriera antimicrobica igienizzante.

COATINGS WITH SILVER ANTIBACTERIAL DEFENSE
We use one-component paints, with free-solvent in water-based without harmful chemicals. Moreover, thanks to additives Silver Defense, the lacquer becomes sanitizing antimicrobial barrier.



TUTTI I COLORI DEL MONDO

Oltre ai 48 laccati opachi e 29 laccati lucidi sono a disposizione 6 essenze e altre finiture nobilitate in diverse tonalità di colore per specifici modelli di anta.

ALL WORLD COLOURS
In addition to the 48 matt and 29 glossy lacquered colors there are 6 essences and other ennobled finture in different shades of color for specific models of door.



DESIGN E PRODUZIONE 100% MADE IN ITALY

Ogni prodotto è progettato e realizzato totalmente in Italia per assicurare un elevato standard qualitativo.

DESIGN AND PRODUCTION 100% MADE IN ITALY
Each product is designed and manufactured entirely in Italy to ensure a high quality standard.



RICICLABILITÀ DEGLI IMBALLI

Tutti gli imballi: polistirolo, cartone e termoretraibile sono riciclabili al 100%.

RECYCALBILITY 'OF PACKAGING
All packaging polystyrene, cardboard and shrink wrap are 100% recyclable.



PANNELLO ECOLOGICO

Il pannello truciolare ecologico realizzato al 100% con legno post-consumo, certificato fsc "100% recycled", e con le più basse emissioni di formaldeide al mondo. Un prodotto sicuro, concepito nel pieno rispetto della natura, sia dal punto di vista della produzione che da quello del consumo.

ECOLOGICAL PANEL
Ecological chipboard panel made in 100% post-consumer wood, certified fsc "100% recycled", and with the lowest formaldehyde emissions in the world. A safe product, conceived in full respect of the nature, both in the production and in the consumption.



STANDARD QUALITATIVI D'ECCELLENZA

Aderire ai più alti standard qualitativi internazionali, garantisce prodotti progettati secondo i migliori criteri di funzionalità, ergonomia e design, consegne sicure e rapide e montaggi efficienti.

QUALITY STANDARDS OF EXCELLENCE
Comply to the highest international quality standards, provides products designed with the highest criteria of functionality, ergonomics and design, safe delivery and quick and efficient assembly.



PROGRAMMA GRAFICO

Unico programma grafico per tutto il Gruppo Spagnol. Grazie a questo software, potrete presentare ai vostri clienti un preventivo preciso accompagnato da rendering.

GRAPHIC PROGRAM
Unique graphics program for the entire Spagnol Group. With this software, you can provide your customers an accurate economic offer accompanied by rendering.



SPAGNOL ON LINE

Il sito web è il punto di riferimento per tutte le informazioni e gli aggiornamenti sui prodotti.

www.spagnol.it

SPAGNOL ON LINE
The website is the reference point for all information and product updates.

Tutte le combinazioni di colori, materiali e finiture

All combinations of colors, materials and finishes

	Frontali SPAZIO	Frontali LIGHT (laccato opaco)	Frontali LACCATO OPACO poro aperto	Frontali LUX (laccato lucido)	Frontali METAL	Anta vetro telaio "0" chimico	Anta vetro telaio Brill	Top vetro sp. 1cm	Top e Mensole	Pedane	Strutture GLOBO	Strutture VEGA GIORNO	Strutture ARMADI SCORREVOLI	Boiserie Orizzontale	Boiserie Verticale	Boiserie Easy	Boiserie Max	Boiserie Fusion	Archimede	Letti	Strutture Comò e Comodini	Pannelli al mq e Scrittoi sp. 3,8 cm	Pannelli al mq sp. 1,8 cm	Sedie	Tavoli	Elementi e Basi universali	Pensili universali	Monoblocchi	
Nob. BIANCO	•							•	•	•	•	•	•	•	•	•	•	•	•	•	•	•	•	•	•	•	•	•	
Nob. MADREPERLA	•							•	•	•	•	•	•	•	•	•	•	•	•	•	•	•	•	•	•	•	•	•	•
Nob. OLMO BIANCO	•							•	•	•	•	•	•	•	•	•	•	•	•	•	•	•	•	•	•	•	•	•	•
Nob. OLMO CANAPA	•							•	•	•	•	•	•	•	•	•	•	•	•	•	•	•	•	•	•	•	•	•	•
Nob. OLMO MONTEGO	•							•	•	•	•	•	•	•	•	•	•	•	•	•	•	•	•	•	•	•	•	•	•
Nob. MANGO	•							•	•					•	•	•	•	•	•	•	•	•	•	•	•	•	•	•	•
Nob. MANDARINO	•							•	•					•	•	•	•	•	•	•	•	•	•	•	•	•	•	•	•
Nob. POMODORO	•							•	•					•	•	•	•	•	•	•	•	•	•	•	•	•	•	•	•
Nob. BAMBU	•							•	•					•	•	•	•	•	•	•	•	•	•	•	•	•	•	•	•
Nob. CARTA DA ZUCCHERO	•							•	•					•	•	•	•	•	•	•	•	•	•	•	•	•	•	•	•
Nob. NUVOLA	•													•	•	•	•	•	•	•	•	•	•	•	•	•	•	•	•
Nob. IRIS	•													•	•	•	•	•	•	•	•	•	•	•	•	•	•	•	•
Nob. GRIGIO	•													•	•	•	•	•	•	•	•	•	•	•	•	•	•	•	•
Nob. SABBIA	•													•	•	•	•	•	•	•	•	•	•	•	•	•	•	•	•
Nob. ROVERE BIANCO	•													•	•	•	•	•	•	•	•	•	•	•	•	•	•	•	•
Laccati OPACO	•							•	•	•	•	•	•	•	•	•	•	•	•	•	•	•	•	•	•	•	•	•	•
Laccati OPACO PORO APERTO		•																											
Laccati LUCIDO			•					•	•	•	•	•	•	•	•	•	•	•	•	•	•	•	•	•	•	•	•	•	•
Laccati METAL				•				•	•	•	•	•	•	•	•	•	•	•	•	•	•	•	•	•	•	•	•	•	•
Vetro ACIDATO						•	•																						
Vetro TRASPARENTE						•	•																						
Vetro BRONZO STOP SOL						•	•																						
Vetro LUCIDO LACCATO						•	•	•																					
Vetro SATINATO LACCATO						•	•																						
PLEXIGLASS						•	•																						

Questa tabella fornisce indicazioni generali sull'impiego di materiali, colori e finiture. Per una effettiva disponibilità consultare il listino prezzi.

This table provides general information concerning used materials, colors and finishes. For a specific availability have a look at the price list.

SPAGNOLmobili



Mobil spa - Spagnol mobili
Via Vidor, 1 - 31010 Mosnigo di Moriago (TV) - ITALY
Tel. +39.0438.89.11 - Fax +39.0438.89.00.82
www.spagnol.it - mobili@spagnol.it