

COLLEZIONE LIVING

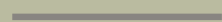

Day Collection

SPAGNOLmobili

Your living space discovers
new proportions thanks to
customizable and versatile
furnishing solutions that satisfy
every need for style and space.

www.spagnol.it

COLLEZIONE
LIVING

Design Spagnol

→ Il living scopre nuove dimensioni,
grazie a sistemi di arredo personalizzabili
e versatili che rispondono ad ogni
esigenza di stile e di spazio.



it
Spagnol Mobili presenta un nuovo concetto di living a cui dare forma combinando tra loro elementi, accessori e finiture. Sistemi a spalla, contenitori e complementi sono pensati per combinarsi in varianti diverse, dando forma a soggiorni personalizzati e su misura.

en
Spagnol Mobili's new living area concept comes to life through the combination of elements, accessories and finishes. The open-end shelving systems, containers and accessories are designed to be combined in different versions to give shape to customized and made-to-measure living rooms.

COLLEZIONE

LIVING

Design Spagnol

←

Vega Day/Vega Night -06

Programma a spalla/Open-end Shelving System

Elementi universali e pensili -08

Universal elements and wall units

Programma contenitori/Storage Systems

Elementi in metallo -09

Metal elements

Programma contenitori/Storage Systems

Boiserie e madie -10

Panelling and sideboards

Complemento/Accessories

Frontali -12

Fronts

Tipologie di frontali/Types of Fronts

VEGA DAY/NIGHT

Programma a spalla/Open-end Shelving System

→ Elementi Vega Day monofacciali/ Vega Night

L'assoluta compatibilità dei programmi Vega Day e Vega Night permette di realizzare con un unico sistema a spalla composizioni di diversa profondità, con vani a giorno oppure chiuse da molteplici tipologie di frontale, per creare un'alternanza funzionale tra pieni e vuoti.

Vega Day/Vega Night Single-sided Elements

The total compatibility between Vega Day and Vega Night allows you to create compositions with different depths, open spaces or closed by different types of fronts for a functional variation between solids and voids, all thanks the open-end shelving system.



→ Ponti Vega Day/Vega Night

La struttura a ponte, disponibile con o senza schienale, combina colonne e vani a giorno sfruttando diverse larghezze e profondità e accoglie una comoda scrivania, per dare forma ad un pratico spazio studio.

Vega Day/Vega Night Bridges

The bridge element, available with or without backs, combines tall units and open spaces using the different widths and depths and a comfortable desk to give shape to a practical study space.



→ Elementi Vega Day Maxi

Gli elementi Vega Day Maxi consentono di creare vani di larghezza maggiore rispetto alle normali colonne Vega Day. Ogni singolo vano può essere dotato di divisori in legno o cristallo. Gli elementi con divisorio in legno possono essere completati con basculanti, ante a ribalta o schienali.

Maxi Vega Day Elements

The Maxi Vega Day elements allow you to create spaces that are bigger than the normal Vega Day tall units. Every single space can be equipped with wood or crystal dividers. The units with the wood dividers can have up and over or flap doors or backs.



→ Elementi Vega Day passanti/ bifacciali

Il programma a spalla passante dà forma a vani a giorno senza schiena che permettono di creare una libreria elegante e leggera. Nella versione bifacciale gli elementi vengono attrezzati con frontali su entrambi i lati.

Open-back/Double-sided Vega Day Elements

The open-end, open-back shelving systems give shape to open spaces without backs to create an elegant and airy bookcase. In the double-sided version, the elements are equipped with fronts on both sides.



→ Elementi sovrapposti Vega Day

Gli elementi sovrapposti posizionati in appoggio sulle basi Vega Day permettono di creare una parete attrezzata in cui si alternano profondità diverse che movimentano la composizione.

Overlapping Vega Day Elements

The overlapping pieces mounted on the Vega Day bases allow you to create an equipped wall unit on which different, alternating depths liven up the composition.



→ Elementi Vega Day sospesi

Gli elementi sospesi a parete danno forma a composizioni leggere e moderne, in cui le colonne possono essere attrezzate con dei frontali per creare degli spazi contenitivi chiusi.

Suspended Vega Day Elements

The suspended wall elements give shape to light, modern compositions in which tall units can be equipped with fronts to create closed storage spaces.



ELEMENTI UNIVERSALI/PENSILI

Programma contenitori/Storage Systems

→ Elementi Universali

Una serie di versatili elementi, disponibili in diverse modularità, che possono essere a giorno oppure completi di frontali o ante in vetro e disposti a terra, in appoggio su altri elementi o sospesi a parete.

Universal Elements

A series of versatile elements, available in different modules, which can be open or complete with fronts or glass doors and floor-mounted or mounted on other elements or suspended on a wall.



→ Pensili

Una vasta gamma di pensili, disponibili con diverse dimensioni e forme, utilizzabili singolarmente oppure in abbinamento agli elementi universali.

Wall Units

A vast array of wall units, available in different sizes and shapes, which can be used singularly or combined with the universal elements.



→ Elementi I-Line

Eleganti elementi da utilizzare a terra, in appoggio o sospesi, caratterizzati da frontali con profilo maniglia orizzontale in metallo, disponibile in finitura Piombo o Laccato.

I-Line Elements

These elegant pieces can be floor and wall-mounted or mounted on other pieces. They are characterized by their fronts with metal profile handles, available with Lead or Lacquered finish.



ELEMENTI IN METALLO

Programma contenitori/Storage Systems

→ Teka (scaffali e pensili)

Gli elementi Teka sono caratterizzati da un telaio in tubo metallico con sezione 1,5 x 1,5 cm in finitura Piombo o Laccato Opaco. Sono disponibili nella versione scaffale oppure in diverse larghezze nella versione pensile.

Teka (bookcases and wall units)

The Teka units are characterized by a 1.5 x 1.5, metal tube frame with a Lead or Matt Lacquered finish. They are available as bookcases or in different widths as wall units.



→ Shell (scaffali sospesi)

Un sistema di scaffali sospesi costituiti da spalle in tubo metallico con sezione 1,5 x 1,5 cm, tra i quali si possono inserire liberamente delle mensole in finitura nobilitato o laccato.

Shell (suspended bookcases)

A system of suspended bookcases composed of open-end, 1.5 x 1.5, metal tubing on which shelves with laminated or lacquered finishes can be inserted.



→ Rio Bassa/Rio Alta (mensole)

Due tipologie di mensole, disponibili con larghezza 90 o 120 cm e altezza a scelta tra 21 cm con fianchi laterali o 8 cm senza fianchi. Il telaio in lamiera può essere personalizzato scegliendo tra tutti i colori delle finiture laccate e aggiungendo delle strisce in led.

Low Rio/High Rio (shelves)

Two types of shelves: 90 or 120 cm wide and 21 cm high with sides or 8 cm without sides. The metal sheet frame can be customized by choosing among all the lacquered finish colours and adding led strips.



BOISERIE

Complemento / Accessories

→ Boiserie Stripe

Un'elegante boiserie formata da pannelli orizzontali e impreziosita da profili in finitura Piombo su cui è possibile inserire nella posizione desiderata delle mensole di spessore 1,2 cm. Disponibile in tutte le finiture, può essere posizionata in appoggio oppure sospesa.

Stripe Panelling

Elegant panelling composed of horizontal panels embellished with profiles with Lead finish. 1.2 cm thick shelves can be added to the composition in any position desired. Available in all the finishes, it can be floor or wall-mounted.



→ Boiserie Max

Costituita da pannelli senza profili d'unione a vista, la boiserie Max è dotata di un vano tecnico sul retro che consente di nascondere i cavi e può essere arricchita da una strip led che illumina il perimetro.

Max Panelling

Composed of panels without visible joining profiles, the Max panelling is equipped with a space on the back to hide the cables and a led strip that illuminates the edges.



MADIE

Complemento / Accessories



→ Madie Regolo

Madie con vani a giorno - Sideboards with open spaces



→ Madie Creek



→ Madie Zelig

Madie con ante - Sideboards with doors



→ Madie Complanari

Coplanar sideboards



→ Madie sospese Trim

Suspended sideboards



→ Madie Riser

FRONTALI

Tipologie / Fronts Types



→ AXEL

Materiali / Material

Frontali sp. 2,2 cm realizzati con pannello in agglomerato di particelle di legno bordato in ABS sp. 1 mm in tinta.

2.2 cm thick fronts made of chipboard panels with 1 mm thick ABS trim of the same colour.

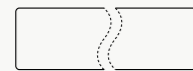

Tipologie di ante / Types of doors

ANTE BATTENTI / Wing doors
ANTE RIBALTA - BASCULANTI / Flap and up & over doors
ANTE SCORREVOLI / Sliding doors
CASSETTI / Drawers
CASSETTONI / Big drawers

Per le dimensioni disponibili fare riferimento al listino prezzi / For available sizes, refer to the price list

Finiture pannello / Panel finishes

NOBILITATI	Laccati Opachi
Bianco	Laccati Opachi Gessato
Madreperla	Laccati Lucidi
Olmo Canapa	Laccati Metal
Noce Sider	Iron
Noce Lloyd	Touch
Noce Cotto	
Rovere Nodato	
Noce Canaletto	
Gessato Bianco	
Gessato Madreperla	
Beton Madreperla	
Beton Sabbia	
Salis	
Sabbia	
Platino	
Grafite	

Disponibile / Available

VEGA DAY
VEGA NIGHT
Elementi universali
 Universal elements
Madie / Sideboards



→ CREEK

Materiali / Material

Frontali sp. 2,2 cm realizzati con pannello in fibra di media densità (MDF).

2.2 cm thick fronts made of MDF panels.



Tipologie di ante / Types of doors

ANTE BATTENTI / Wing doors
ANTE RIBALTA - BASCULANTI / Flap and up & over doors
ANTE SCORREVOLI / Sliding doors
CASSETTI / Drawers
CASSETTONI / Big drawers

Per le dimensioni disponibili fare riferimento al listino prezzi / For available sizes, refer to the price list

Finiture pannello / Panel finishes

Laccati Opachi

Disponibile / Available

VEGA DAY
Elementi universali
 Universal elements
Madie Creek / Creek Sideboards



→ STONE

Materiali / Material

Frontali sp. 2,2 cm realizzati con pannello in agglomerato di particelle di legno bordato in ABS sp. 1 mm in tinta.

2.2 cm thick fronts made of chipboard panels with 1 mm thick ABS trim of the same colour.



Tipologie di ante / Types of doors

ANTE BATTENTI / Wing doors
ANTE RIBALTA - BASCULANTI / Flap and up & over doors
ANTE SCORREVOLI / Sliding doors
CASSETTI / Drawers
CASSETTONI / Big drawers

Per le dimensioni disponibili fare riferimento al listino prezzi / For available sizes, refer to the price list

Finiture pannello / Panel finishes

Bianco Statuario
 Nero Marquinia

Disponibile / Available

VEGA DAY
Elementi universali
 Universal elements
Madie
 (escluso Creek - Creek excluded)

FRONTALI

Tipologie / Fronts Types



→ OMEGA

Materiali / Material

Frontali sp. 2,2 cm realizzati con pannello in agglomerato di particelle di legno bordato in ABS sp. 1 mm in tinta. Profili verniciati in alluminio finitura Bianco, Piombo o nei colori laccati opaco.

2.2 cm thick fronts made of chipboard panels with 1 mm thick ABS trim of the same colour. Varnished aluminium profiles with White or Lead finish or in the matt lacquered colours.

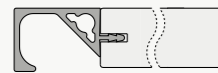

Tipologie di ante / Types of doors

ANTE BATTENTI / Wing doors
CASSETTI / Drawers
CASSETTONI / Big drawers

Per le dimensioni disponibili fare riferimento al listino prezzi / For available sizes, refer to the price list

Finiture pannello / Panel finishes

NOBILITATI	Laccati Opachi
Bianco	Laccati Opachi Gessato
Madreperla	Laccati Lucidi
Olmo Canapa	Laccati Metal
Noce Sider	
Noce Lloyd	
Noce Cotto	
Rovere Nodato	
Noce Canaletto	
Gessato Bianco	
Gessato Madreperla	
Beton Madreperla	
Beton Sabbia	
Salis	
Sabbia	
Platino	
Grafite	

Disponibile / Available

VEGA NIGHT



→ ANTA VETRO SESTANTE / GLASS DOOR

Materiali / Material

Telaio in alluminio
Vetro sp. 0,4 cm

Aluminium frame
0.4 cm thick glass

Finiture vetro / Glass finishes

Grigio Europa

Finiture telaio / Frame finishes

Metal Grey

Disponibile / Available

VEGA DAY

VEGA NIGHT

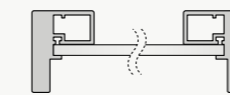

Tipologie di ante / Types of doors

ANTE BATTENTI / Wing doors

Per le dimensioni disponibili fare riferimento al listino prezzi / For available sizes, refer to the price list



→ UNICA

Materiali / Material

VERSIONE NOBILITATO:
Pannello sp. 2,2 cm in agglomerato di particelle di legno bordo in ABS sp.1 mm in tinta.

VERSIONE SPECCHIO:
pannello sp. 1,8 cm (caratteristiche come sopra) con specchio sp. 0,4 cm applicato frontalmente.

PROFILI MANIGLIA VERTICALI:
in alluminio finitura Bianco o Piombo o nei colori laccato opaco

LAMINATED VERSION:
2.2 cm thick chipboard panel with 1 mm thick abs trim of the same colour

MIRROR VERSION:
1.8 cm thick panel (same characteristics as above) with 0.4 cm thick mirror applied on the front.

VERTICAL PROFILE HANDLES:
in aluminium with White or Lead finish or in the matt lacquered colours.

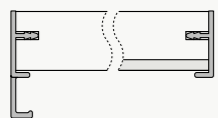

Tipologie di ante / Types of doors

ANTE BATTENTI / Wing doors

Per le dimensioni disponibili fare riferimento al listino prezzi / For available sizes, refer to the price list

Finiture pannello / Panel finishes

NOBILITATI:	Laccati Opachi
Bianco	Laccati Opachi Gessato
Madreperla	Laccati Lucidi
Olmo Canapa	Laccati Metal
Noce Sider	Specchio
Noce Lloyd	
Noce Cotto	
Rovere Nodato	
Noce Canaletto	
Gessato Bianco	
Gessato Madreperla	
Beton Madreperla	
Beton Sabbia	
Salis	
Sabbia	
Platino	
Grafite	

Disponibile / Available

VEGA NIGHT



→ ANTA VETRO / GLASS DOOR

Materiali / Material

Telaio in alluminio
Vetro sp. 0,4 cm

Aluminium frame
0.4 cm thick glass

Finiture vetro / Glass finishes

Trasparente
Grigio Europa
Laccati Lucidi:
Bianco
Platino
Madreperla
Salis
Sabbia
Fango
Grigio Londra
Grigio Cenere
Grafite
Antracite

Finiture telaio / Frame finishes

Piombo

Disponibile / Available

VEGA DAY

VEGA NIGHT

Elementi universali
Universal elements

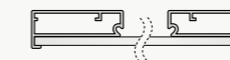

Tipologie di ante / Types of doors

ANTE BATTENTI / Wing doors

Per le dimensioni disponibili fare riferimento al listino prezzi / For available sizes, refer to the price list

Five different varieties of furniture for five home concepts. Five different styles that all share the same principle: a mixture of character, customization and functionality.

— Collezione Living

index

→ Cinque tipologie di arredo per cinque concetti di casa. Cinque stili diversi che condividono lo stesso principio: una commistione di carattere, personalizzazione e funzionalità.

Prestige

18 – 69

Modern

70 – 127

Loft

128 – 167

Young

168 – 213

Nordic

214 – 245

Madie

246 – 267

Tavoli . Tavolini . Sedie

268 – 281

Technical Detail

282 – 300

Pagine di sintesi

301 – 311

— Collezione
Living



it

→ La casa è un'oasi di eleganza sobria e raffinata, dove il design assume una dimensione domestica. Per vivere la quotidianità in ambienti in cui tutto è in perfetta armonia: gli spazi, l'arredo, i colori.

en

→ The home is an oasis of calm and refined elegance where design becomes part of the walls. Live your everyday life in rooms where everything is in harmony: spaces, furniture, colours.

Design Spagnol

Regalarsi ogni giorno un pizzico di straordinario.

Give yourself the gift of extraordinariness every day.

Pre. sti ge — home design

Prestige —

home design

→ La zona giorno è un grande spazio in cui gli arredi distinguono i diversi ambienti e le diverse funzioni, sempre con gusto ed eleganza.

The living room is a great space in which the furniture differentiates the different areas and functions, always tastefully and elegantly.



it

→ La flessibilità del programma spalla Vega permette di creare una grande parete attrezzata che termina in una libreria passante con divisori in vetro, perfetta per separare gli ambienti senza appesantirli.



The flexibility of the open-end Vega shelving system allows you to create a big equipped wall unit that is completed with an open-back bookcase and glass shelves, perfect to divide the area with airiness.





→ Living_801

L 389,1 x 423
P 35,5
H 227,2

Sabbia
Noce Cotto
Magnolia



Living Room /

→ I frontali in Noce Cotto sulla struttura color Sabbia e il vano con ripiani in finitura Magnolia danno ritmo e carattere alla composizione.



The Toasted Walnut fronts on the Sand frame and the open space with Magnolia finish shelves give rhythm and character.



→ Living_802

L 407,8
P 35,5
H 227,2

Noce Cotto
Magnolia

it

→ Lo schienale ed i ripiani color Magnolia rompono lo schema regolare dei vani a giorno, aggiungendo un tocco di stile all'eleganza del sistema a ponte.

en

→ The Magnolia finish back and shelves break up the scheme of the open spaces by adding a touch of style to the elegant bridge system.



→ Living_803

L 377,8
P 48,3
H 195,2

Noce Cotto, Luce,
Anta vetro con telaio
Piombo e vetro
trasparente/door Glass
with frame Piombo
and glass transparent



→ Le ante in vetro si alternano ai frontali e lasciano intravedere il dettaglio del profilo a led sui ripiani.

The glass doors alternate with the fronts showing the detail of the led strip on the shelves.

→ L'elevata flessibilità dei sistemi a spalla dà forma ad arredi che sanno essere al contempo unici e versatili.

The highly flexible open-end shelving systems give shape to pieces that are both unique and versatile at the same time.

Living_804 ←

L 362,8

P 35,5

H 195,2

Sabbia

Noce Canaletto



→ Le due grandi ante scorrevoli
 in finitura Noce Canaletto, attraversate
 da raffinate venature verticali,
 possono scorrere per nascondere l'area
 dedicata al televisore.

The two big sliding doors
 with Canaletto Walnut
 finish and refined vertical
 veining can close off the
 television space.



Living_805

Parete attrezzata
Equipped wall unit

L 420
P 2,5/25/34,4/47,2
H 161,2

Madreperla, Grafite,
Verde Militare





La boiserie Stripe sostiene delle mensole sugli eleganti profili in finitura Piombo.

The Stripe panelling supports shelves on the elegant, Lead finish profiles.



it

→ La composizione è sofisticata e attuale, caratterizzata da eleganti toni Grafite e Madreperla e tocchi di Verde Militare.

The composition is sophisticated and current with its elegant Graphite and Mother of Pearl tones and touches of Military Green.



Il top sporge oltre la profondità della scocca, arrivando a filo con il frontale del cassetto.

The top is deeper than the frame to become flush with the drawer front.



→ Living_806

L 270
P 19/34,4
H 161,2

Madreperla - Noce Canaletto
Anta vetro con telaio Piombo
e vetro Grigio Europa/door
Glass with frame Piombo
and glass Grigio Europa

→ La chiave della composizione è la leggerezza, data dagli elementi sospesi e dalla trasparenza delle ante in vetro.

The key to this composition is its delicacy thanks to the suspended elements and the transparency of the glass doors.

→ Living_807

L 360
P 25/34,4/47,2
H 122,2

Lucido Ocra
Nero Marquina
Sabbia



it

→ Un design funzionale per rendere la zona giorno estremamente pratica.

This functional design makes the living room extremely practical.



→ Living_808

Librerie
Bookcases

L 182,8
P 33
H 195,2

Sabbia



→ Suntuose, le venature della finitura Nero Marquinia attraversano gli elementi della base sospesa.

The veining of the Black Marquinia finish across the elements of the suspended base is luxurious.

Living_809 ←

L 662,8
P 48,3
H 291,2

Fango, Madreperla,
Verde Laguna





→ Ripiani in cristallo con illuminazione led e sfumature delicate bilanciano l'imponenza della composizione.

Crystal shelves with led lighting and delicate shades balance out the grandness of the composition.



→ Living_810

L 330
P 34,4/47,2
H 180

Madreperla
Menta



→ La disposizione libera di elementi universali e pensili con dimensioni diverse, a terra e in sospensione, crea un insieme originale e dinamico.

The open positioning of the different-sized universal elements and wall units, floor-mounted or suspended, create an original and dynamic unit.



Living Room /
→ I toni neutri accostati arredano un ambiente fresco e luminoso che invita al relax.



The neutral tones alongside the embellish a fresh and bright, relaxing space.

→ Living_811

L 360
P 19,4/34,4/47,2
H 180

Noce Lloyd, Salis
Lucido Bianco



it

→ Il topic della composizione è un accurato studio dei volumi, che emerge dall'accostamento delle mensole sottili con le dimensioni importanti dei pensili.

en

→ The theme of the composition is a precise combination of volumes which is obvious in this mix of thin shelves with the significant size of the wall units.





→ Living_812

L 390
P 19,4/47,2
H 215

Noce Sider
Salis



Living Room /

→ Un angolo studio dal marcato andamento orizzontale e dai toni luminosi.

A study area which has a clear horizontal line and bright tones.

Living_813 ←

L 345
P 4/34, 4/47, 2
H 150,7

Noce Sider
Verde Laguna
Madreperla

→ **Essenziale ed elegante nelle proporzioni, l'arredo del living punta su pochi elementi e finiture di tendenza.**

Essential and elegant in its size, the design of this living room counts on only a few elements and trendy finishes.





→ La finitura a contrasto fa risaltare i pensili a giorno 1.2, che interrompono la compattezza degli elementi universali con ante.

The contrast in finish enhances the open 1.2 wall unit which interrupts the solidity of the universal elements with doors.



→ Living_814

L 360
P 34,4/47,2
H 180

Noce Lloyd, Grafite,
Giada, Anta vetro con
telaiio Piombo e vetro
Grigio Europa/door Glass
with frame Piombo
and glass Grigio Europa

it

→ Il design degli arredi e la grande attenzione ai dettagli caratterizza lo stile di una zona giorno sofisticata e al contempo informale.

en

→ The design of the furnishings and the great attention to detail is a sign of style of this sophisticated, yet informal, living space.



— Collezione
Living



it

→ Come risposta alla frenesia della vita di oggi, nasce il bisogno di ambienti che trasmettono tranquillità. La casa moderna è fatta di spazi luminosi e tonalità neutre, a cui si aggiunge il colore distribuito in tocchi strategici e misurati.

en

→ To counterbalance today's hectic lifestyle, there is a need for tranquil spaces. Modern homes are composed of bright spaces and neutral tones with just the right amount of added touches of strategically-placed colour.

Design Spagnol

Vivere il presente, al passo con le ultime tendenze.

Living in the present in tune with the latest trends.

Mp
de
rn —

home
design

Modern —

home design

→ Un living a tema "primavera in città": modulato su scala di grigi, con accenti pastello e dettagli luminosi.

A "spring in the city" living space composed of shades of gray with pastel accents and bright details.

it

→ Il design ultrasottile e moderno delle mensole Rio è completato dall'aggiunta di strisce led nella parte inferiore.



The ultra-thin and modern design of the Rio shelves is refined with the addition of led strips underneath.



→ Living_815

L 345
P 34,4/47,2
H 215

Noce Sider
Salis
Ruggine





→ La cura per i dettagli si nota anche dagli elementi funzionali, come il comodo passacavi che si integra nell'arredo.

Attention to detail is also in the functional elements, like the convenient cable grommet integrated in the unit.



→ **Living_816**

L 330
P 17,3/25/34,4/47,2
H 180

Noce Sider
Luce, Sabbia

→ Un living essenziale con un tocco creativo, dato dall'alternanza asimmetrica di pensili chiusi e elementi a giorno e dalla lavorazione dei frontali Creek nelle basi a terra.

An essential living space with a creative touch coming from the asymmetric variation of the closed and open wall units and the surface of the Creek fronts on the floor-mounted bases.



it

→ La particolarità dell'anta Creek trasforma il carattere dell'arredo aggiungendo una vena elegante ad una composizione minimal e moderna.



The peculiarity of the Creek door transforms the essence of the decor by adding an elegant streak to a minimal and modern composition.



it

→ Le ante in vetro con telaio color Piombo e la predominanza del grigio danno all'arredo un particolare sapore metropolitano.



The glass doors with Lead colour frame and the predominance of grey add a particularly urban flavour to the room.

→ **Living_817**

L 300
P 25/34,4
H 120

Noce Sider, Sabbia, Anta vetro con telaio Piombo e vetro Grigio Europa/door Glass with frame Piombo and glass Grigio Europa

it

→ I dettagli colorati dei moduli a giorno animano il design simmetrico della madia Regolo, ripreso ed enfatizzato dalle mensole Rio color Antracite.

en

→ The coloured details of the open modules liven up the symmetrical design of the Regolo sideboard, enhanced also by the Anthracite Rio shelves.

→ Living_818

L 182,4
P 25/47,2
H 175

Noce Sider
Ruggine
Antracite



→ Living_819

Parete attrezzata
Equipped wall unit
L 405
P 34,4/47,2
H 200

Madia Zelig
L 182,6 - P 47,2 - H 66,4

Luce, Fango e Anta vetro
con telaio Piombo e vetro
Grigio Europa, grafica
"Illusion" su madia/door
Glass with frame Piombo
and glass Grigio Europa
graphic "Illusion" on
sideboard



it

→ Un colore tenue e delicato accentua il senso di leggerezza della madia sospesa e l'anta decorata gli dà carattere.

en

→ A soft and subtle colour accentuates the sense of airiness of the suspended sideboard and the decorated door gives it character.



→ Living_820

Parete attrezzata
Equipped wall unit

L 300
P 29,6/47,2
H 200

Elementi sospesi
Suspended elements

L 121,9
P 34,4
H 192

Grafite
Sabbia
Ocra



it
→ La finitura Ocra si dispone in punti strategici per portare un pizzico di vivace luminosità nella zona living.

The Ochre finish is placed in strategic points to bring a touch of brightness to the living room.

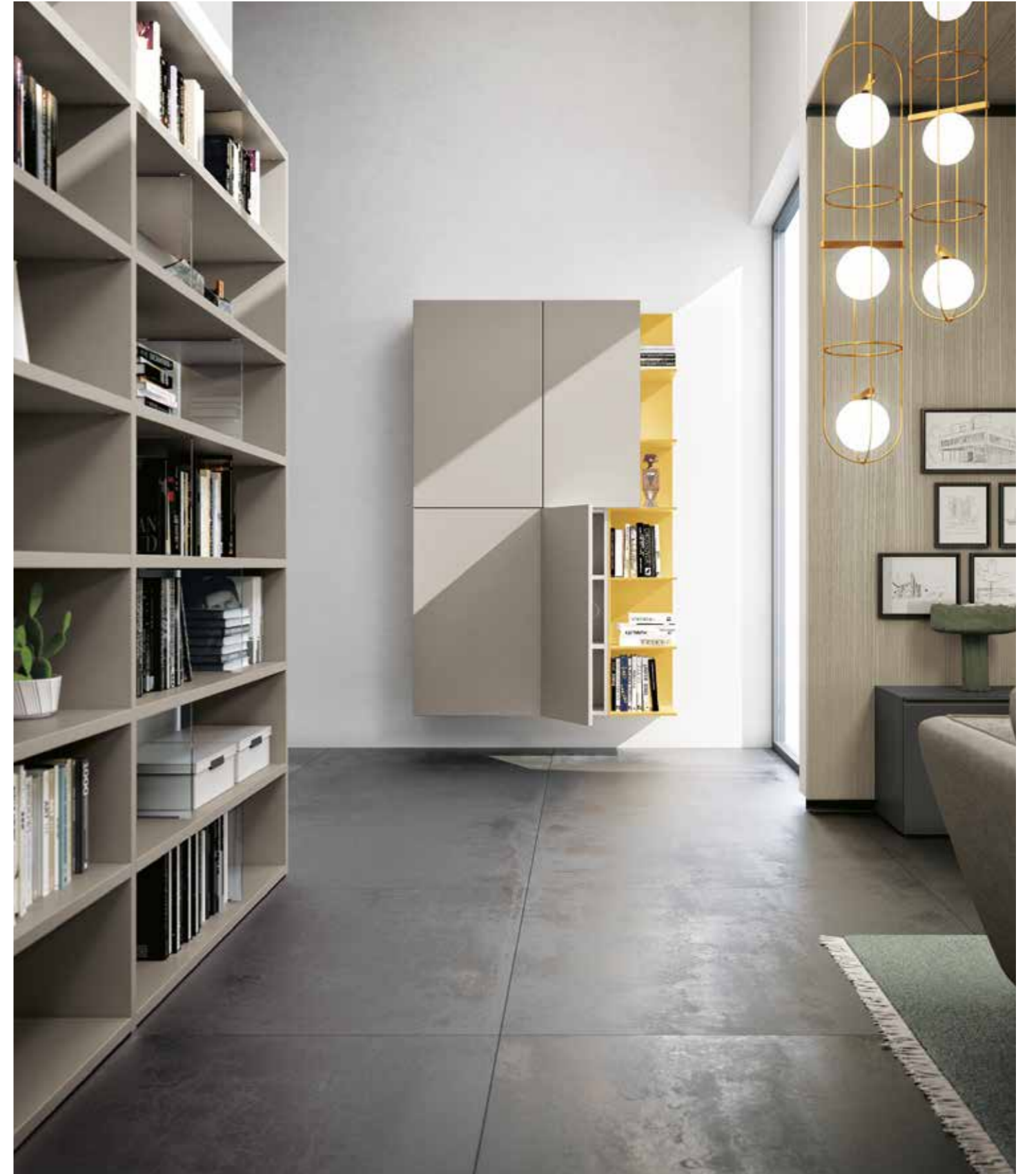

Living_821 ←

Parete attrezzata
Equipped wall unit

L 360
P 4/25/34,4/47,2
H 161,2

Madia Regolo
L 182,4
P 47,2
H 68,4

Fango, Salis
Cognac



it

→ Il minimalismo dell'arredo trova la sua particolare poesia nell'equilibrio tra i volumi e nel raffinato gioco di proporzioni tra gli elementi.

en

→ The minimalism of the furniture finds its harmony in the balance between size and the refined play on the proportions of the elements.





Living_822 ←

L 270
P 34,4
H 192

Noce Sider
Cognac



Living Room /

→ I pensili a giorno 1.2 scavano nel volume pieno, creando delle comode nicchie.

The open 1.2 wall units dig into the solid space creating convenient recesses.



→ Living_823

L 360
P 29/34,4
H 161,2

Verde Laguna
Rovere Nodato
Madreperla



it

→ I moduli bifacciali Vega Day maxi separano gli spazi in modo fluido e non appesantiscono gli ambienti, grazie alle finiture che si modulano su tonalità fresche e leggere.

The maxi, double-sided Vega Day modules separate the spaces fluidly making the atmosphere light thanks to the finishes whose hues are fresh and light.

→ Living_824

L 332,8
P 35,5
H 227,2

Madreperla
Verde Laguna
Luce



→ Living_825

L 332,8
P 33
H 227,2

Noce Cotto



→ In un'area living dominata da colori naturali, sono gli arredi a definire i confini e le funzioni degli spazi.

In a living room dominated by natural colours, it is the decor that defines the lines and functions of the space.

it

→ Il programma a spalla passante è completato da delicati divisori in cristallo, che con la loro trasparenza alleggeriscono la struttura in Noce Cotto.

en

→ The open-back, open-end shelving system is enhanced with crystal dividers whose transparency lightens the structure in Toasted Walnut.



→ Living_826

L 512,8
P 36,7
H 195,2

Sabbia, Nero Marquinia e
anta Sestante con
telaio Metal Grey e vetro
Grigio Europa /door
Sestante with frame
Metal Grey and glass
Grigio Europa



it

→ L'imponente parete Vega Day è scandita da colonne ed elementi sovrapposti di varie dimensioni, a giorno o chiusi con ante sui quali si mescolano diversi materiali e finiture.

en

→ The impressive Vega Day wall piece is articulated in tall units and overlapping elements of different sizes, open or closed with doors of different materials and finishes.



it

→ Un incontro inaspettato tra vetro, led e venature:
una combinazione originale per dare carattere alla parete.

A surprising mix of glass, led lights
and veining: an original combination
which sets off the wall.

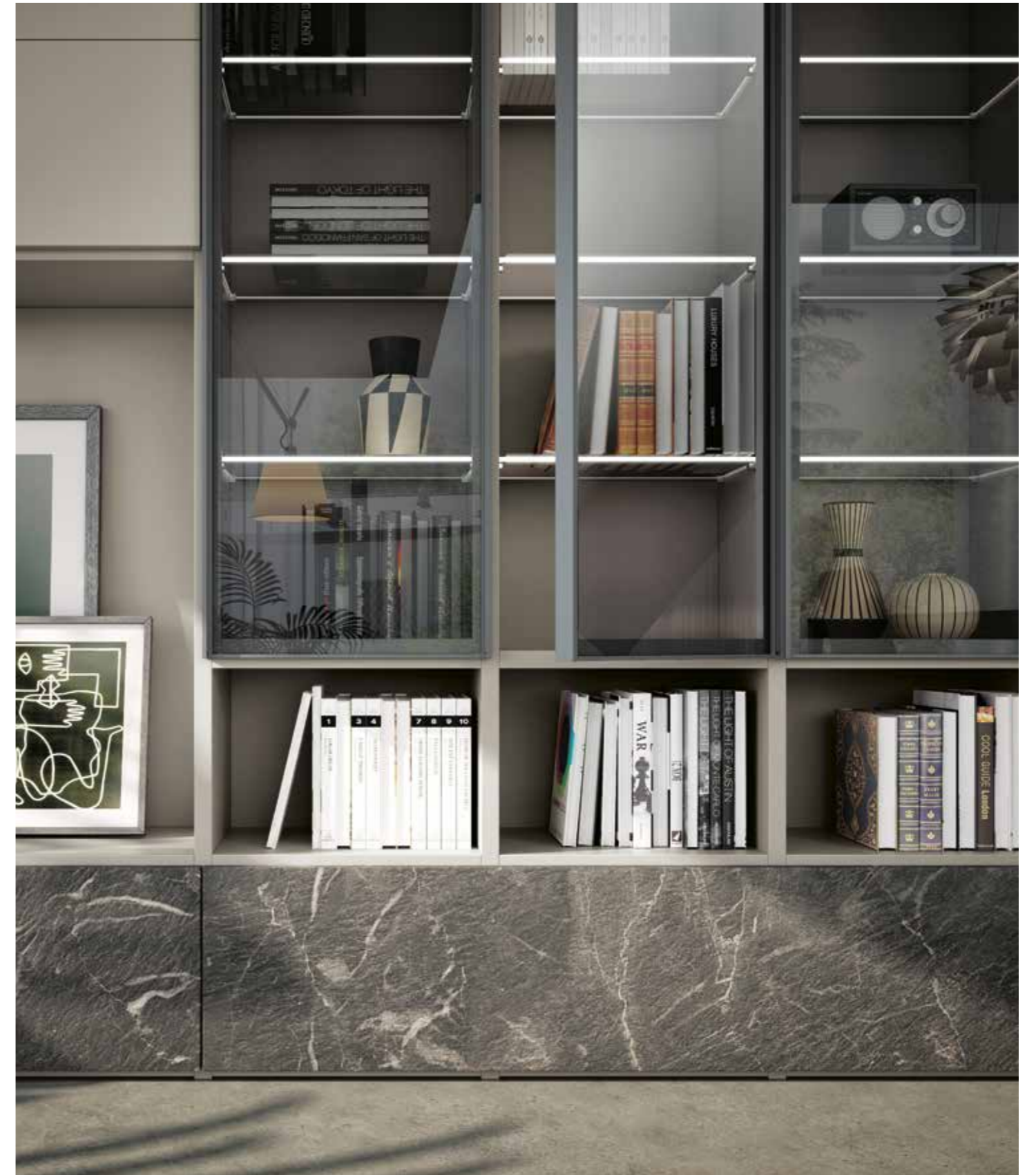

→ Living_827

L 420
P 2,5/25/34,4/47,2
H 165,6

Grigio Londra
Noce Cotto



→ L'andamento orizzontale della composizione è sottolineato dai profili in finitura Piombo sulla boiserie Stripe.

The horizontal flow of the composition is accentuated by the Lead finish profiles on the Stripe panelling.



→ Living_828

L 360
P 25/34,4/47,2
H 160

Lucido Prugna
Verde Militare

it

→ Il living fa spazio al colore: l'arredo sorprende grazie a una tonalità vivace e al tocco glamour del laccato lucido.

The living area gives way to colour: the furniture is featured thanks to the lively shade and the touch of glamour of the glossy lacquer.



→ Living_829

Parete attrezzata
Equipped wall unit
L 360
P 4/34, 4/47, 2
H 161,2

Madia Regolo
L 182,4
P 47,2
H 68,4

Noce Lloyd
Magnolia
Sabbia



→ Essenza e laccati dai toni chiari rivestono la parete attrezzata sospesa e riecheggiano sulla madia.

Wood and light-toned lacquers grace the suspended equipped wall unit and are echoed on the sideboard.

it
→ **Un design moderno e dal sapore romantico
modulato su toni primaverili.**

A modern, but romantic
look in spring tones.



— Collezione
Living



it

→ **Grandi open space invasi dalla luce, che entra in abbondanza da finestre e vetrate. Abitazioni versatili, da arredare scegliendo pezzi minimal che giocano sulla disposizione e sull'accostamento di tonalità e materiali.**

en

→ **Great open spaces penetrated by the light coming from the glass doors and windows. Versatile homes furnished with select minimal pieces that play with the layout and combination of shades and materials.**

Design Spagnol

Un unico grande spazio, per tutti i momenti della quotidianità.

One, big space for your everyday moments.

Lo
fit

— home
design

Loft —

home design

→ Il concept dell'ambiente ruota intorno alla leggerezza, che si esprime attraverso la scelta di moduli sospesi e di una palette glaciale.

The concept of the space is airiness which is expressed through the choice of suspended modules and icy colours.

it

→ La versatilità delle colonne Vega abbinata ad elementi universali e pensili permette di arredare tanto la zona giorno quanto la zona notte, creando un ambiente uniforme ed equilibrato.



The versatility of the Vega tall units combined with the universal elements and wall units allow you to decorate both your living room and bedroom, creating a uniform and balanced atmosphere.



→ Living_830

Parete attrezzata
Equipped wall unit
L 345
P 4/19,4/34,4/47,2
H 180

Madia Trim
L 62,4
P 34,4
H 194,4

Verde Militare
Fango





→ I pensili a giorno 1.2 si inseriscono nel design compatto della composizione, alleggerendola e vivacizzandola con tocchi di colore.

The open 1.2 wall units integrate with the compact design of the composition, lightening and livening it up with touches of colour.



→ Frontali battenti e scorrevoli di diverse dimensioni rivestiti con una finitura tattile e sensoriale, per una libreria di carattere.

Wing and sliding doors of different sizes with a tactile and sensorial finish for a bookcase with personality.



→ Living_831

L 392,8
P 35,5
H 227,2

Cognac
Touch Madreperla
Verde Militare



→ L'originalità del design si rivela in ogni dettaglio.

The originality of the design is revealed in every detail.



→ Living_832

L 300
P 25/35,5
H 180

Cognac
Touch Madreperla



→ Living_833

L 452,8
P 36,7
H 291,2

Noce Lloyd, Verde
Militare e anta Sestante
con telaio Metal Grey
e vetro Grigio Europa /
door Sestante with
frame Metal Grey
and glass Grigio Europa



it

→ La grande libreria Vega Day in Noce Sider è resa sofisticata dall'uso del vetro, mentre gli elementi sospesi Vega rompono lo schema geometrico con moduli a giorno in finitura a contrasto.

The big Vega Day bookcase in Sider Walnut is sophisticated thanks to the use of glass while the suspended Vega elements soften the geometrical scheme with open spaces in contrasting finishes.



→ **Living_834**

L 362,8
P 35,5
H 99

Noce Lloyd
Verde Militare

→ Living_835

Libreria
Bookcase
L 482,8
P 4/33/48,3
H 163,2

Madie Trim
L 62,4
P 34,4
H 194,4

Bianco
Touch Bianco
Magnolia



it
→ **La parete con elementi Vega sovrapposti a giorno contribuisce a creare una composizione leggera e luminosa.**

The wall unit with overlapping, open Vega elements helps create a light and bright composition.





→ La combinazione di elementi Vega Day a terra e sovrapposti crea una struttura inedita, valorizzata dalla finitura Bianco Statuario.

The combination of floor-mounted and overlapping Vega Day elements is an original structure, enhanced by the Statue White finish.

→ Living_836
L 407,8
P 33/48,3
H 131,2
Platino
Bianco Statuario

it

→ Le venature eleganti e delicate del Bianco Statuario incontrano un design moderno e pulito: un effetto inedito e ricercato per la zona giorno.



The elegant and delicate veining of the Statue White finish combines with a modern and clean design: an original and refined effect for your living room.

→ Living_837

L 390
P 19/34,4/47,2
H 209,2

Grigio Londra
Menta



it

→ Gli schienali Padi ospitano mensole dallo spessore sottile, disposte in modo asimmetrico: tutto parla di leggerezza e di stile.

en

→ The Padi backs support thin shelves, placed asymmetrically for a light and stylish look.



→ Living_838

L 315
P 34/47,2
H 185

Platino
Menta
Limone



Living Room /

→ I pensili Teka sono protagonisti della parete, con il loro originale telaio in tubo metallico dai toni pastello.

The Teka wall units dominate the wall with their original metal tube frame in pastel colours.

→ Le proporzioni e la delicatezza della parete attrezzata ingentiliscono una zona giorno dall'anima urban.

The proportions and the elegance of the equipped wall unit grace this urban style living room.



→ Living_839

L 360
P 19/34,4/47,2
H 151,9

Noce Sider
Luce
Blu



it

→ Un design funzionale per rendere la zona giorno estremamente pratica: lo spazio viene organizzato con moduli capienti e per ogni base o pensile si può scegliere l'apertura più comoda e agevole.



A functional layout that makes the living room very practical: the space is organized with capacious pieces and you can choose the most handy and simple openings for the bases and wall units.



→ Living_840

L 450
P 34,4/47,2
H 240

Sabbia
Rovere Nodato
Ocra

it

→ La composizione gioca con le dimensioni e le disposizioni degli elementi universali sospesi e con il tocco colorato dei pensili Kubik 2 a giorno.

en

→ The composition plays with the size and layout of the suspended universal elements and with the touch of colour of the open Kubik 2 wall units.

→ Living_841

L 360
P 25/34,4/47,2
H 190

Sabbia
Beton Sabbia
Magnolia



— Collezione
Living



it

→ **Un concetto di casa liquido, caratterizzato dalla filosofia della condivisione. Spazi fluidi, in cui si mixano funzioni, materiali e colori di tendenza. Il risultato è un ambiente composito modulato sullo stile dei vita young.**

en

→ **The concept of a fluid home characterized by shared space. Flowing spaces where functions, materials and trendy colours mix together. The result is a mixed area based on a young lifestyle.**

Design Spagnol

Fare spazio ad abitudini, passioni, progetti ed esperienze.

Make way for habits, passions, projects and experience.

**Yo
un
g** — **home
design**

Young —

home design



→ Una casa giovane è una casa fresca e luminosa, caratterizzata da arredi funzionali che seguono le ultime tendenze.

A youthful home is cool and bright and characterized by functional and trendy decor.

it

→ Scaffali sospesi Shell per la zona notte e scaffali Teka per la zona giorno. Due complementi dal design attuale e dal sapore industrial.



Suspended Shell shelves in the bedroom and Teka shelves in the living room. Two modern accessories, but with an industrial vibe.





→ **Living_842**

L 360
P 34,4/47,2
H 165

Grigio Cenere
Blu



it

→ **La libertà compositiva non ha limiti e il living diventa uno spazio da personalizzare.**

The freedom of composition has no limits and your living area becomes customizable.





→ Living_843

3 Scaffali Teka
L 700
P 34
H 186,7

Piombo
Grigio Londra

it

→ Grazie al telaio in tubo metallico, il trittico di scaffali Teka va a formare una libreria destrutturata perfetta per gli ambienti moderni.

en

→ Thanks to the metal tube frame, the three Teka set of shelves form a deconstructed bookcase perfect for modern spaces.



→ Living_844

L 362,8
P 35,5/48,3
H 195,2

Fango
Salis
Rovere Nodato



it

→ Gli elementi Vega day monofacciali possono essere personalizzati con frontali che chiudono i vani a giorno e i cassettoni, aumentando la funzionalità.

en

→ The single-sided Vega Day elements can be customized with fronts that close the open spaces and big drawers to increase functionality.





Living_845 ←

L 332,8
P 35,5
H 163

Bianco
Rovere Nodato



Living_846 ←

L 360
P 34,4/47,2
H 210

Luce, Magnolia
Odra, Madrepra
Olmo Canapa

it

→ **Gli elementi universali a terra si sviluppano in lunghezza utilizzando un top in due diversi spessori per creare un'ampia base d'appoggio.**

The floor-mounted universal elements stretch in length with a top of two different thicknesses to create a wide support base.





→ Originale e fuori dagli schemi: la zona giorno riflette lo stile di chi la abita giocando con i vari elementi dell'arredo.

Original and out-of-the-box: the living area reflects the homeowner's style by playing with different elements.

→ **Living_847**

Parete attrezzata	Madie Trim
Equipped wall unit	
L 360	L 62,2
P 25/34,4/47,2	P 34,4
H 180	H 162,4

Salis
Magnolia



Living Room /

→ Le madie sospese Trim completano l'ambiente.

The suspended Trim sideboards perfect the room.



→ **Living_848**

L 390
P 34,4/47,2
H 200

Sabbia
Madreperla
Noce Canaletto





→ Living_849

L 360
P 19/20/34,4/47,2
H 210

Luce
Blu
Bianco

it

→ Trendy e delicata: la composizione esprime il proprio carattere scegliendo una disposizione dinamica degli elementi sospesi e colori light.

en

→ Trendy and delicate, this composition shows its character through a dynamic arrangement of the suspended elements and light colours.



→ La modularità degli arredi permette di creare una comoda zona studio, perfettamente integrata nell'ambiente.

The modularity of the furniture allows you to create a comfortable study area, perfectly integrated with the room.

Living_850 ←

Parete attrezzata	Madia
Equipped wall	Creek
L 420	L 122,4
P 25/34,4/47,2	P 47,2
H 193,2	H 116,4

Grafite, Fango
Noce Lloyd



Living Room /

→ I dettagli colorati animano il design della madia Creek e dell'angolo studio.

The coloured details give light to the design of the Creek sideboard and the study corner.

→ Creare un piccolo e funzionale ufficio in casa è facile con la modularità degli elementi Vega Day sospesi.

Creating a small, functional office at home is easy with the modularity of the suspended Vega Day elements.

→ Living_851

L 347,8
P 35,5/47,2
H 163

Grafite



→ Living_852

L 442
P 25,4
H 196

Fango
Verde Militare





it
→ **Design e praticità si incontrano nella grande libreria che sfrutta i toni del Fango e del Verde militare per creare uno stile unico e divertente.**

Design and practicality come together in the big bookcase whose Mud and Military Green colours create a unique and fun style.

→ **Living_853**

Parete Shell Madia
Shell wall Zelig
L 1615 x 2525 L 152,4
P 25,4 P 47,2
H 128 H 66,4

Bianco
Giada
Noce Canaletto



— Collezione
Living



it

→ **Armonia, purezza e naturalezza:**
i tre concetti chiave dello stile nordico sono
quelli che lo rendono un trend senza tempo,
amato e interpretato in case e appartamenti
a qualsiasi latitudine.

en

→ **Harmony, purity and nature:** the three key
concepts of the Nordic style are the ones that
make it a timeless trend, loved and displayed
in homes and flats at any latitude.

Design Spagnol

La bellezza scandinava è di casa.
Scandinavian beauty fits right in.

**No
rd
ic** —

**home
design**

Nordic —

home design

→ Nella zona giorno nordica domina la luminosità: bianco, colori pastello e legno chiaro sono must have irrinunciabili.

Brightness dominates Nordic living rooms: white, pastel colours and light-coloured wood are undeniable must haves.

it

→ L'arredo si compone di pochi elementi scelti con cura in base alla loro funzione e al loro stile, disposti in modo da creare un ambiente semplice e molto accogliente.



The decor is composed of a few carefully selected elements for function and style, arranged so as to create a simple and very welcoming space.



→ Living_854

Parete attrezzata
Equipped wall unit
L 360
P 34/34,4
H 170

Sabbia
Madreperla
Noce Sider

Pensili Teka
ed elementi universali
Teka wall units and
universal elements
L 900
P 34/34,4
H 96



→ **Living_855**

L 392,8
P 35,5
H 163

Madreperla
Sabbia
Noce Sider



it

→ Sulla composizione si alternano moduli aperti e moduli chiusi da frontali in essenza, in laccato opaco o nella finitura materica Touch Madreperla.

en

→ This composition has a variety of modules: open and closed with fronts in wood, matt lacquered or Mother of Pearl Touch finish.

→ **Living_856**

L 180
P 34/34,4
H 128

Sabbia
Noce Canaletto
Touch Madreperla



→ Living_857

L 360
P 34/34,4/47,2
H 170

Menta
Laguna
Bianco



→ Living_858

L 542,8
P 48,3/60
H 259,2

Noce Sider
Giada
Touch Sabbia





Living Room /

→ Una finitura materica per questo frontale Omega, con presa maniglia in alluminio laccato.

A material finish for this Omega front with aluminium lacquered grip handle.

it
 → **Basi I-Line a terra e quattro mensole Rio, nelle versioni alta e bassa: la composizione è semplice e delicata, in perfetto mood nordico.**

Floor-mounted I-Line bases and four Rio shelves in the high and low versions: the combination is simple and delicate, perfect for the Nordic mood.



→ **Living_859**

L 360
 P 25/47,2
 H 150

Grafite
 Giada

it

→ Sono i dettagli più piccoli a caratterizzare l'ambiente, come l'illuminazione led applicata alle mensole Rio e la particolare presa maniglia sulle basi I-Line a terra.

en

→ The smallest details mark the space: the led lighting applied to the Rio shelves and the particular grip handle on the floor-mounted I-Line bases.



→ Un arredo minimal e allo stesso tempo caldo dà un'interpretazione elegante e sofisticata allo stile scandinavo.

A minimal, but at the same time, warm decor brings elegance and sophistication to this room with a Nordic feel.



Living_860 ←

L 290
P 25/34,4/47,2
H 170

Fango
Iron Corten
Noce Canaletto



Living Room /

→ I capienti cassettoni sulla base rendono la composizione funzionale oltre che bella.

The ample big drawers of the base make this composition both functional and beautiful.



→ Living_861

L 437,8
P 33/47,2
H 195,2

Prugna
Madreperla
Gessato Madreperla





→ **Living_862**

L 286,2x1500
P 19/34,4/47,2
H 180

Sabbia
Rovere Nodato

→ Living_863

L 365,6
P 4/25/48,3
H 195,2

Fango
Gessato Fango
Iron Ottone



— Collezione
Living

it

→ **Sospesa o a terra, resa elegante da scelte cromatiche inedite, sdrammatizzata dall'uso delle grafiche: esiste la madia perfetta per ogni ambiente.**

en

→ **Suspended or floor-mounted, elegant thanks to the choice of original colours, softened by the use of graphic elements: there is a perfect sideboard for every room.**

Madie

Design Spagnol

La madia, un classico dell'arredamento, torna alla ribalta nelle case di oggi.

The sideboard, a classic piece, makes a comeback in today's homes.

space
design

Madie Creek



it

→ **La madia non è un semplice elemento con funzione contenitore, ma dialoga con lo stile della composizione e le conferisce carattere.**

The sideboard does not only function as a container, but confers with the style of the composition and gives it character.



← **Madia_864**
versione sospesa
suspended version
L 182,4
P 47,2
H 50,4

Grafite
Verde Laguna

Madia Creek nella versione
con basamento
Creek sideboard in the
version with base

it

→ I toni delicati del Menta e del Salis e il motivo decorativo del frontale Creek ammorbidiscono l'intero assetto geometrico.

en

→ The delicate Mint and Salis shades and the decorative element of the Creek front soften the entire geometrical layout.

Madia Creek nella versione a terra
Creek sideboard in the floor-mounted version



Madia_865 →
versione con basamento
version with base
L 122,4
P 47,2
H 116,4
Salis
Noce Sider
Menta

Madie Creek



Madie Regolo



it
 → Lo sviluppo orizzontale ricorda le dinamiche del gioco dei "regoli" e costruisce una piacevole alternanza tra spazi pieni e vuoti.

The horizontal flow recalls the dynamics of the Cuisenaire rods and creates pleasant variations between solids and voids.



← **Madia_866**
 versione sospesa
 suspended
 L 182,4
 P 47,2
 H 74,4
 Noce Lloyd
 Ruggine

Madia Regolo nella versione
 con basamento
 Regolo sideboard in the
 version with base

Madie Regolo

→ **Madia_867**

coppia madie
pair of sideboards

L 152,4
P 47,2
H 68,4

Luce
Blu





→ **Madia_868**
 coppia madie
 couple sideboards
 L 62,4
 P 34,4
 H 194,4
 Bianco
 Magnolia

Madie Trim

sospese - suspended

it

→ Le nicchie che spezzano la compattezza dei volumi verticali, le simmetrie e il match di colori a contrasto conferiscono alla madia un carattere moderno.

en

→ The modern feel of this sideboard comes from the open units that break up the vertical compactness, the symmetry and the combination of contrasting colours.



Madie Zelig



← **Madia_869**
 versione con basamento
 version with base
 L 122,4
 P 47,2
 H 84,4
 Fango
 Madreperla
 Sabbia

it
 → **Le madie con frontali di larghezze diverse, colorati o in soluzioni monocromatiche, sono perfette anche abbinate, per un tocco fresco e giovane.**

The sideboards with different-sized fronts, whether in coloured or monochrome, are perfect for a fresh, young touch.



Madia Zelig nella versione con basamento
 Zelig sideboard in the version with base

Madie Zelig



Madie Zelig nella versione con basamento
Zelig sideboard in the version with base

it

→ Ante e/o cassetti: la funzionalità incontra il design nella progettazione degli spazi della madia.

Doors and/or drawers: functionality meets design in the layout of the spaces of the sideboard.



Madie Zelig nella versione a terra
Zelig sideboard, floor-mounted

← **Madia_870**
 versione sospesa
 suspended
 L 182,4
 P 47,2
 H 66,4
 Limone

Madie Zelig

it
→ Madie da personalizzare con grafica,
scegliendo dall'ampia gamma
dei colori laccati opachi.

Sideboard personalised in a vast range
of matt lacquered colours.



Grafica Optical



Grafica Illusion



Grafica Vintage



Grafica Rombo



→ **Madia_871**
versione a terra
floor-mounted
L 122,4
P 47,2
H 99,9

Bianco - Madreperla
Grafica Optical



Madie Riser

it
 → **Mix and match di effetto marmo, venature e colore in un'unica soluzione, per uno stile che osa, dal carattere unico e moderno.**

Mix and match: marble effect, veining and colours in one solution for a daring style, unique and modern.



← **Madia_872**
 versione con basamento
 version with base
 L 182,4
 P 48,4
 H 70,4
 Lucido Platino
 Noce Canaletto



Madia Complanare

it

→ Le forme lineari e pulite sono avvolte da colori neutri e si inseriscono in una composizione living essenziale e semplice.

The linear and clean flow is surrounded by neutral colours and matches perfectly in this elegant and simple living room composition.



← **Madia_873**
versione a terra
floor-mounted

L 182
P 46,8
H 78

Menta

Madia Complanare nella versione
con basamento

Complanare sideboard in the
version with base

— Collezione
Living

it

→ **Un'ampia scelta di tavoli e tavolini in diverse forme, misure e altezze e una selezione di sedie dallo stile unico. Ma anche panche e poltroncine per completare la zona giorno con complementi coordinati e in linea con le ultime tendenze.**

en

→ **A wide array of tables and coffee tables in different shapes and sizes and a unique selection of chairs; but also, benches and armchairs which perfect the living area with coordinated and trendy pieces.**

Tavoli Tavolini Sedie

Design Spagnol

Tables / Coffee tables / Chairs

home
design



ZIPPO

Tavolo/Table



Tavolo fisso/Fixed table
L. 140/160/180/210 _ P. 90 _ H. 72 cm

Struttura e Piano/Structure and desktop



TOP

Tavolo/Table



L. 90 _ P. 90 _ H. 73 cm
L. 120/140 _ P. 80 _ H. 73 cm

Piano/Desktop top

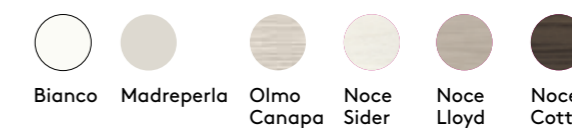

Gambe/Legs



WOOD

Tavolo/Table



Tavolo allungabile/Extendable table
L. 140+40 (1 allungo) _ P. 80 _ H. 77 cm
L. 160+40 (1 allungo) _ P. 80 _ H. 77 cm



Tavolo Quadrato allungabile/Extendable square table
L. 90+90 (allungabile a libro/flip-top)
P. 90 _ H. 79 cm



Tavolo quadrato fisso/Square table
L.90_P. 90 _ H. 77 cm

Struttura e Piano/Structure and desktop



DIAMANTE

Tavolo/Table



Tavolo allungabile/Extendable table
 L. 140+60 _P. 90 _ H. 76 cm
 L. 160+60 _P. 90 _ H. 76 cm
 L. 180+60 _P. 90 _ H. 76 cm

Piano/Desk top



Struttura /Structure



DELTA

Tavolo/Table



Tavolo allungabile/Extendable table
 L. 140+40+40+40 (3 allunghi) _P. 80 _ H. 75,5 cm

Piano/Desk top



Struttura/Structure



THOR

Tavolo/Table



Tavolo fisso/Fixed table
 L. 200 _ P. 100 _ H. 75 cm
 L. 240 _ P. 100 _ H. 75 cm

Piano/Desk top



Struttura/Structure



JOLLY

Tavolo/Table



Tavolo allungabile/Extendable table
 L. 140+40+40+40 (3 allunghi) _P. 80 _ H. 75,5 cm

Piano/Desk top



Struttura/Structure



OTELLO

Tavolo/Table



Tavolo allungabile/Extendable table
 L. 140+40+40 (2 allunghi) _P. 90 _ H. 76,5 cm
 L. 160+40+40 (2 allunghi) _P. 90 _ H. 76,5 cm
 L. 180+40+40 (2 allunghi) _P. 90 _ H. 76,5 cm

Piano/Desk top



Struttura/Structure



ZEN

Tavolo/Table



Tavolo allungabile/Extendable table
 L. 140+40+40+40 (3 allunghi) _P. 80 _ H. 75,5 cm

Piano/Desk top



Struttura/Structure



PONTE Piccolo
PONTE Grande



L. 42 _ P. 42 _ H. 40 cm
L.120 _ P. 60 _ H. 40 cm

Struttura/Structure



Bianco Piombo Laccato opaco

Piano/Desk top



Bianco Madreperla Olmo Canapa Noce Sider Noce Lloyd Noce Cotto Laccato opaco

TOP



L.120 _ P. 60 _ H. 43 cm

Gambe/Legs



Bianco Piombo

Piano/Desk top



Bianco Madreperla Olmo Canapa Noce Sider Noce Lloyd Noce Cotto

ROTONDO Alto
ROTONDO Basso



ø 45 _ H. 64 cm ø 45 _ H. 45 cm

Struttura /Structure



Bianco Piombo Laccato opaco

Piano/Desk top



Laccato opaco

HAPPY ISLAND Alto
HAPPY ISLAND Basso



ø 50 _ H. 30 cm ø 50 _ H. 50 cm

Struttura /Structure



Bianco Piombo Laccato opaco

Piano/Desk top



Laccato opaco

GAMBA INCLINATA



L.42 _ P. 42 _ H. 46 cm

Struttura/Structure



Bianco Piombo Laccato opaco

Piano/Desk top



Bianco Madreperla Olmo Canapa Noce Sider Noce Lloyd Noce Cotto Laccato opaco

ZIPPO



L.50 _ P. 50 _ H. 33 cm
L.120 _ P. 70 _ H. 33 cm

ZIPPO Rotondo



Rotondo ø 60 _ H.45 cm
Rotondo ø 90 _ H.33 cm

Struttura e piano/Structure and desk top



Bianco Madreperla Olmo Canapa Noce Sider Noce Lloyd Noce Cotto Laccato opaco

TEKA rettangolare alto
TEKA rettangolare basso



L. 50 _ P. 40 _ H. 60 cm
L. 70 _ P. 40 _ H. 40 cm

Struttura/Structure



Bianco Piombo Laccato opaco

Piano/Desk top



Bianco Madreperla Olmo Canapa Noce Sider Noce Lloyd Noce Cotto Laccato opaco

TEKA rotondo alto
TEKA rotondo basso



ø 50 _ H. 53 cm
ø 70 _ H. 32 cm

Struttura/Structure



Bianco Piombo Laccato opaco

Piano/Desk top



Laccato opaco

SIRIO

L. 50 _P. 50 _ H. 86 cm (totale/total)
H. 47 cm (seduta/sitting)

Struttura in plastica/Plastic frame



Bianco Creta Antracite

TATA

L. 43 _P. 51 _ H. 85 cm (totale/total)
H. 45 cm (seduta/sitting)

Struttura in metallo/Metal structure

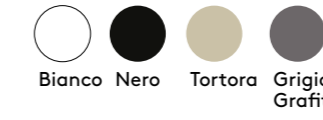

Bianco Nero Tortora Grigio Grafite

Seduta e schienale in plastica/Plastic seat and back seat



Bianco Nero Tortora Grigio Grafite Grigio Chiaro

EMI

L. 48,5 _P. 50 _ H. 83,5 cm (totale/total)
H. 46 cm (seduta/sitting)

Struttura in plastica/Plastic frame



Bianco Creta Antracite Grigio Chiaro

ELENA con gambe/legs

L. 50 _P. 55 _ H. 84 cm (totale/total)
H. 45 cm (seduta/sitting)

Struttura in metallo/Metal structure



Bianco Nero Tortora Grigio Grafite

Seduta e schienale in plastica/Plastic seat and back seat



Bianco Nero Tortora Grigio Grafite Grigio Chiaro

GIULIA

L. 47 _P. 51 _ H. 88 cm (totale/total)
H. 44 cm (seduta/sitting)

Struttura seduta e schienale rivestiti in cuoio rigenerato non sfoderabile/
Seat and back with non-removable, bonded leather covering

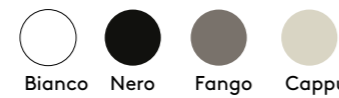

Bianco Nero Fango Cappuccino

ELENA con slitta/con slitta

L. 53 _P. 51 _ H. 84 cm (totale/total)
H. 45 cm (seduta/sitting)

Struttura in metallo/Metal structure



Bianco Nero Tortora Grigio Grafite

Seduta e schienale in plastica/Plastic seat and back seat



Bianco Nero Tortora Grigio Grafite Grigio Chiaro

JENNY

L. 43,5 _P. 51 _ H. 79,5 cm (totale/total)
H. 45 cm (seduta/sitting)

Struttura in metallo/Metal structure



Bianco Piombo

Seduta e schienale in plastica/Plastic seat and back seat



Bianco Creta Antracite



CLOE imbottita/upholstered chair
L. 47 _P. 53 _ H. 88 cm (totale/total)
H. 46 cm (seduta/sitting)

Struttura in metallo/Metal structure

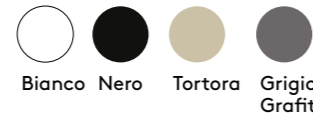

Rivestimento seduta e schienale sfoderabile/
Removable seat and back covers



JENNY imbottita/upholstered chair
L. 43,5 _P. 51 _ H. 81 cm (totale/total)
H. 48 cm (seduta/sitting)

Struttura in metallo/Metal structure



Rivestimento seduta e schienale non sfoderabile/
Non-removable seat and back covers



MS001 imbottita/upholstered chair
L. 46 _P. 51 _ H. 99,5 cm (totale/total)
H. 48 cm (seduta/sitting)

Struttura in legno/ Wood frame



Rivestimento seduta e schienale sfoderabile/
Removable seat and back covers



MS001/B con balza/chair with ruffle
L. 46 _P. 51 _ H. 99,5 cm (totale/total)
H. 48 cm (seduta/sitting)

Struttura in legno/ Wood frame



Rivestimento seduta e schienale sfoderabile/
Removable seat and back covers



PANCHETTA ZIPPO
L. 120 _P. 47,8 _ H. 45 cm
L. 160 _P. 47,8 _ H. 45 cm

Struttura in legno/ Wood frame



Rivestimento cuscino sfoderabile/
Removable seat covering



PANCHETTA THOR
L. 230 _P. 40 _ H. 45 cm

Struttura in metallo/Metal structure



Seduta / Seat



Rivestimento cuscino sfoderabile/
Removable seat covering



**ADELE**

L. 54 _P. 60 _ H. 83 cm (totale/total)

Gambe in legno
Wood legsLaccato
opacoRivestimento seduta e schienale non sfoderabile
Non-removable seat and back covering

Tessuto Ecopelle

**MELODY**

L. 70 _P. 75 _ H. 90 cm (totale/total)

Gambe in legno
Wood legsLaccato
opacoRivestimento seduta e schienale non sfoderabile
Non-removable seat and back covering

Tessuto Ecopelle

**NEST** con slitta/con slittaL. 58,5 _P. 53 _ H. 76,5 cm (totale/total)
H. 46 cm (seduta/sitting)Struttura in metallo/
Metal structure

Bianco Antracite

Rivestimento seduta e schienale non sfoderabile
Non-removable seat and back covering

Tessuto

**NEST** con basamento/con basamentoL. 58,5 _P. 53 _ H. 76,5 cm (totale/total)
H. 46 cm (seduta/sitting)Struttura in metallo/
Metal structure

Alluminio lucidato

Rivestimento seduta e schienale non sfoderabile
Non-removable seat and back covering

Tessuto



— Collezione
Living

Technical — Detail

it

→ Il design della living collection firmata Spagnol propone un'ampia gamma di elementi d'arredo disponibili in diverse finiture, forme e misure e modulabili tra loro per personalizzare con stile la propria composizione.

en

→ The design aesthetic of the Spagnol Living Collection offers a wide array of modular furnishing elements available in various finishes, shapes and sizes to be customized to your own personal style.

Finiture —

Nobilitati per struttura/frontali/accessori Melamine facing for frames/fronts/accessories



Nobilitati per frontali/accessori Melamine facing for fronts/accessories

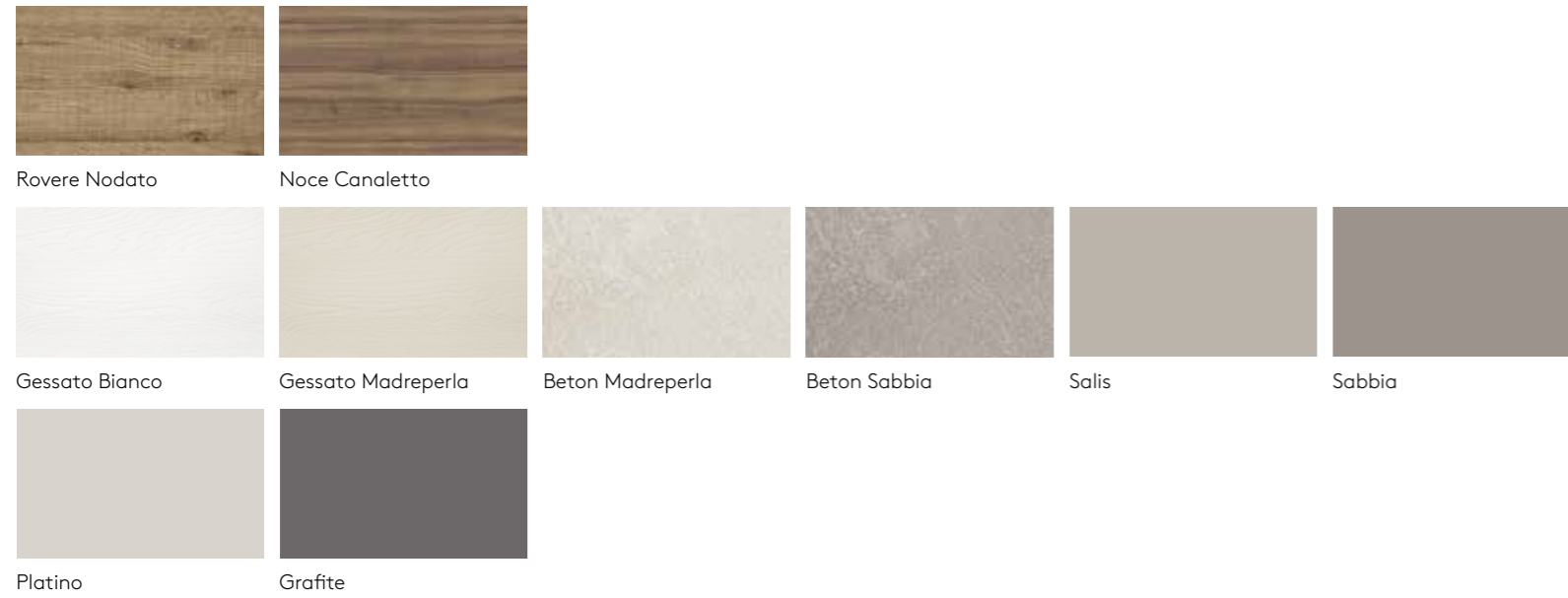

Nobilitati per frontali "Stone" Melamine facing for "Stone" fronts



Nobilitati per cassettiere interne e schiene Vega Night Melamine facing for internal drawers and Vega Night backs



Tipologia di laccatura per strutture e frontali Lacquer types for frames and fronts



Colori laccati Lacquered colours



Laccati opachi a riferimento Matt lacquer per client's reference



Laccato opaco RAL - RAL matt lacquer
Laccato opaco a riferimento - Matt lacquer per client's reference

Finiture —

Laccati Metal per struttura / frontali Metal lacquer for frame / fronts



Perla Metallizzato Gold Metallizzato Titanio Metallizzato Alluminio Metallizzato Piombo Metal Grey

Iron per frontali Iron finish for fronts



Bronzo Ottone Corten

Touch per frontali Touch finish for fronts



Touch Bianco Touch Madreperla Touch Sabbia

Vetri Glass



Trasparente Grigio Europa

Specchio Mirror

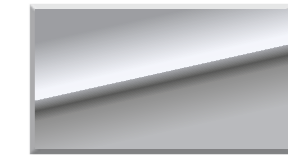

Argentato

Vetri laccati Lacquered glass

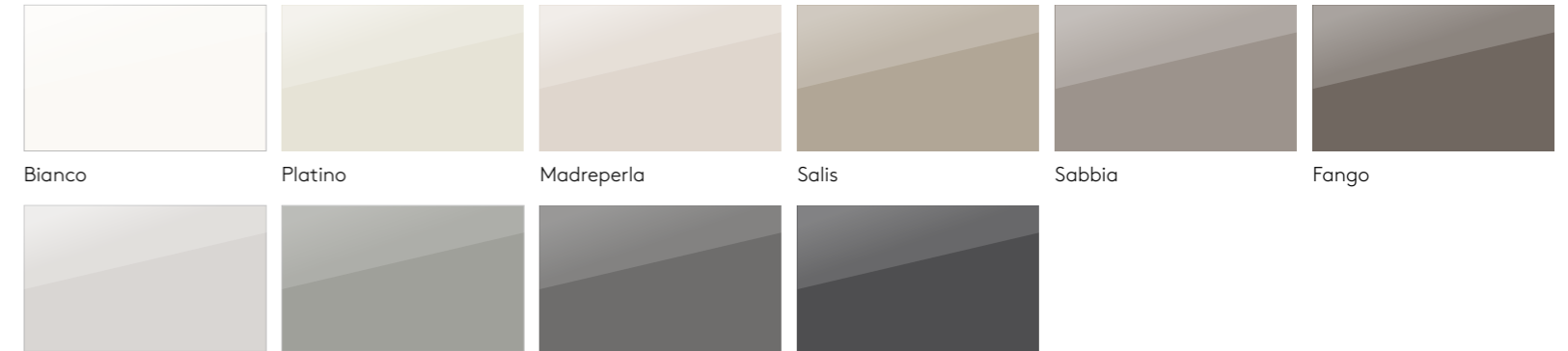

Bianco Platino Madreperla Salis Sabbia Fango

Grigio Londra Grigio Cenere Grafite Antracite

SERIGRAFIE MOVIE/ Movie silk-screen printing

Vintage

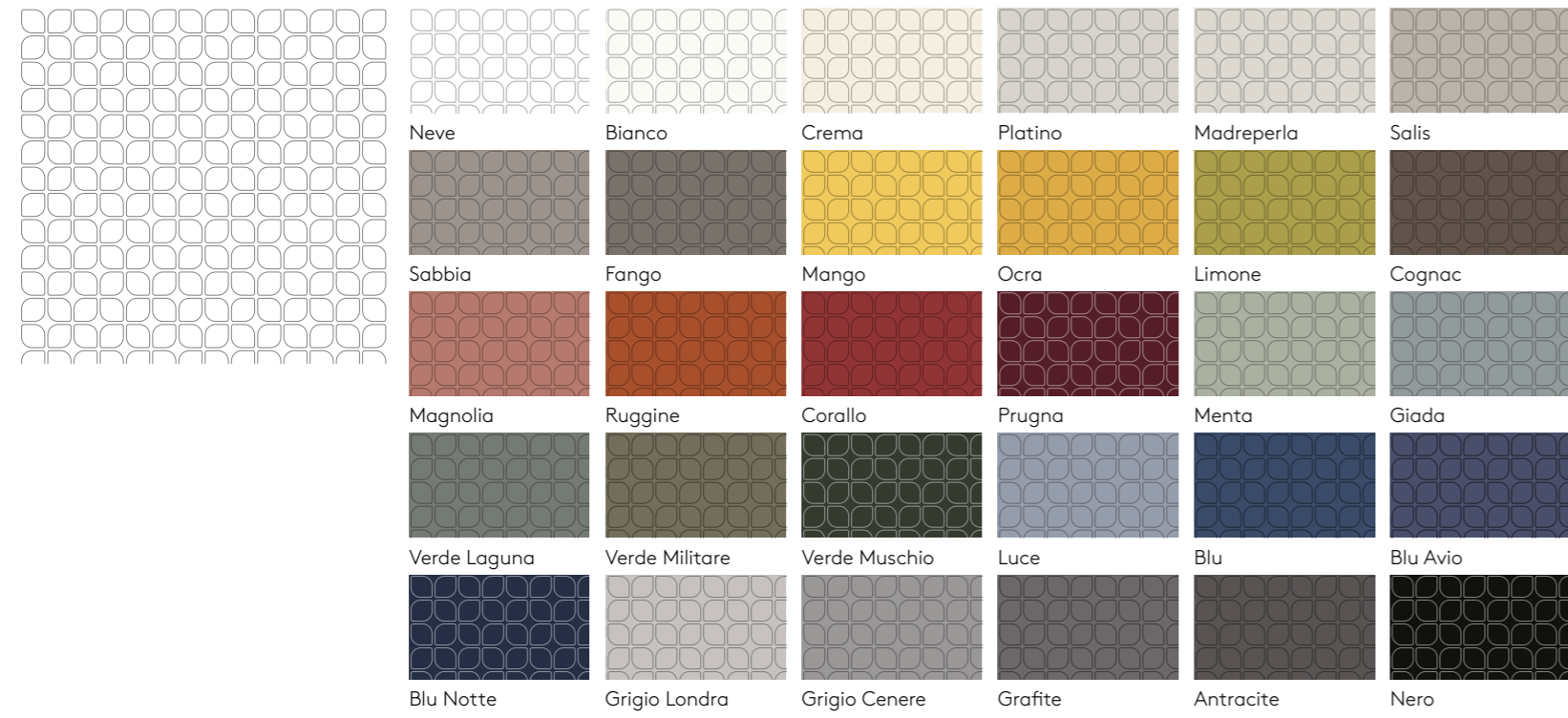

Rombo

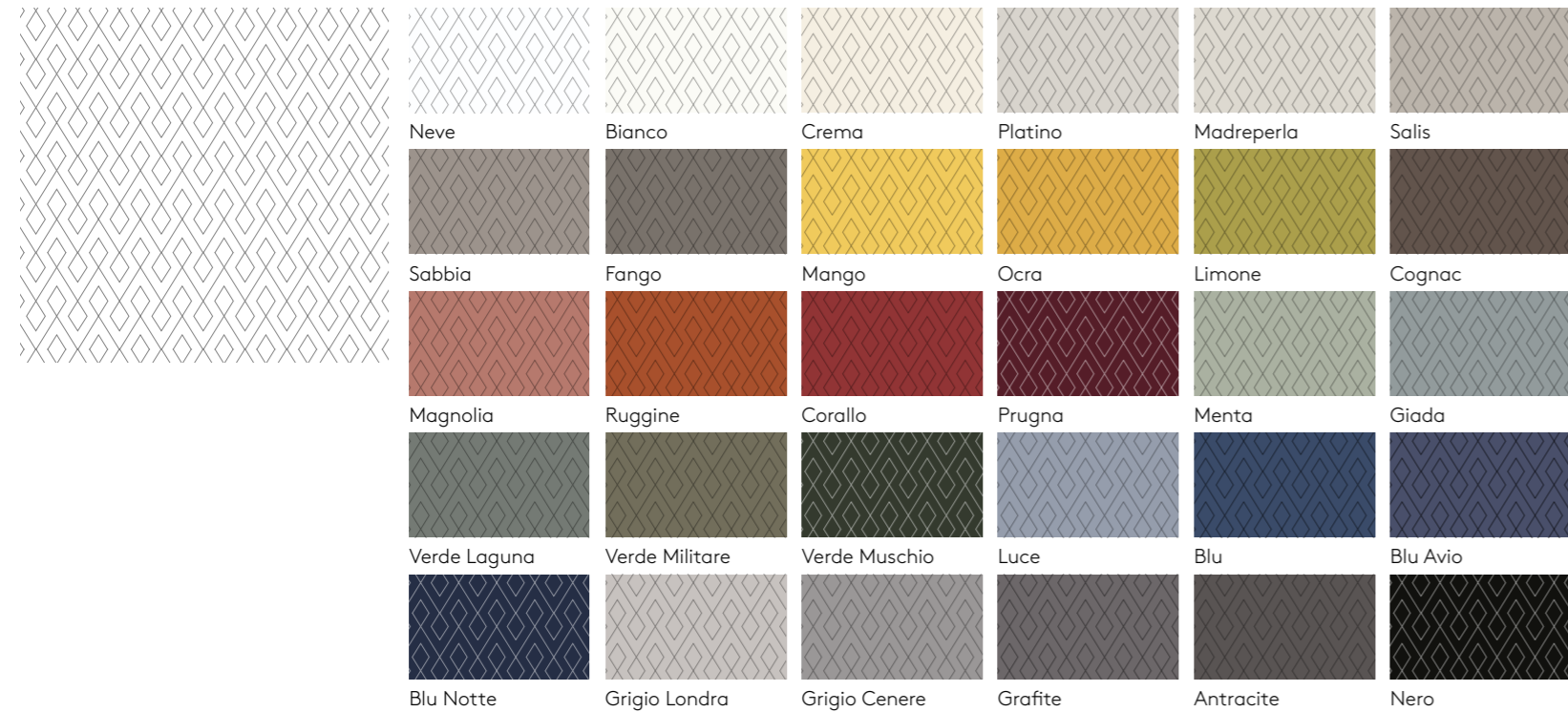

N.B. : È inoltre possibile realizzare serigrafie di qualsiasi immagine desiderata, facendola pervenire alla Spagnol Mobili sotto forma di file ad alta definizione
 N.B. Silk-screen printing of any image desired is also possible by sending Spagnol Mobilia high definition file

Illusion

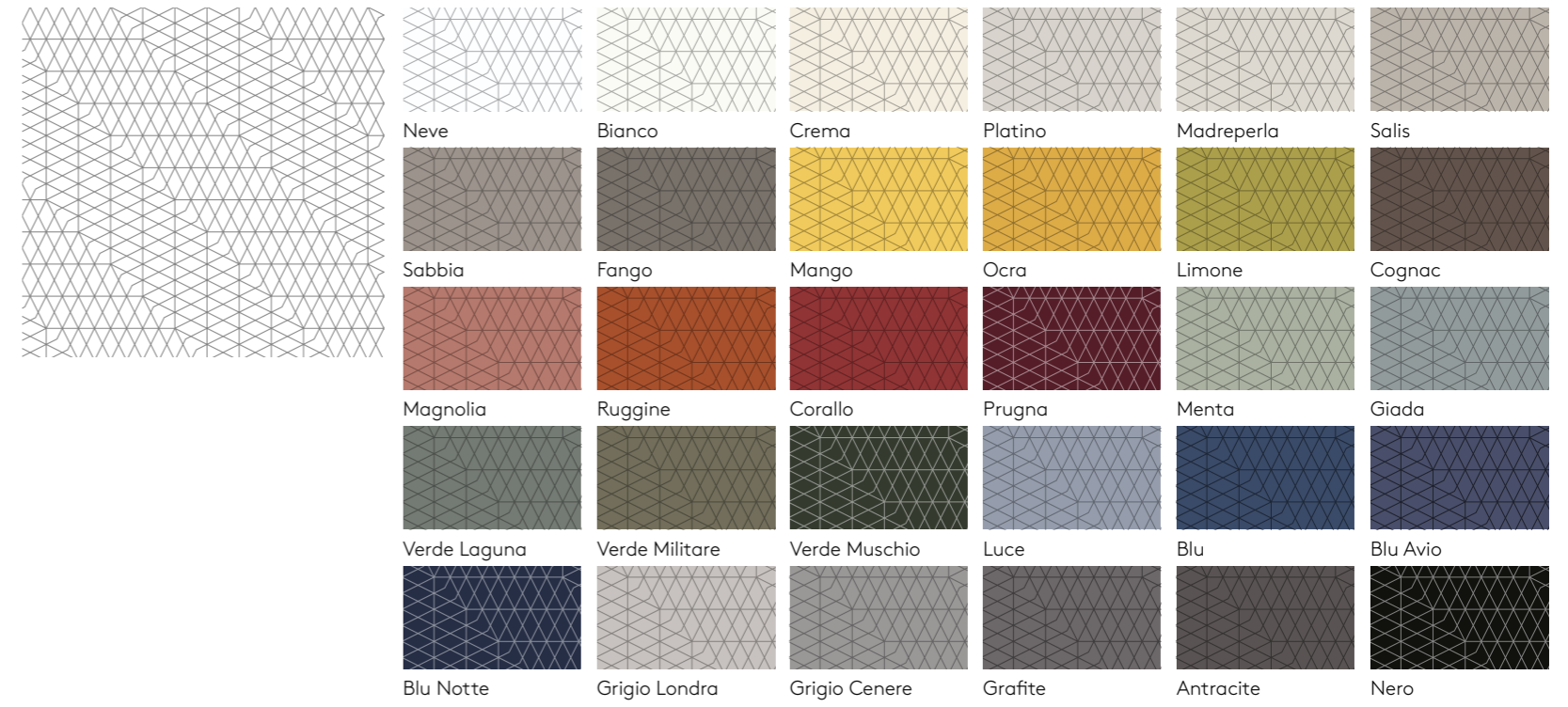

Optical

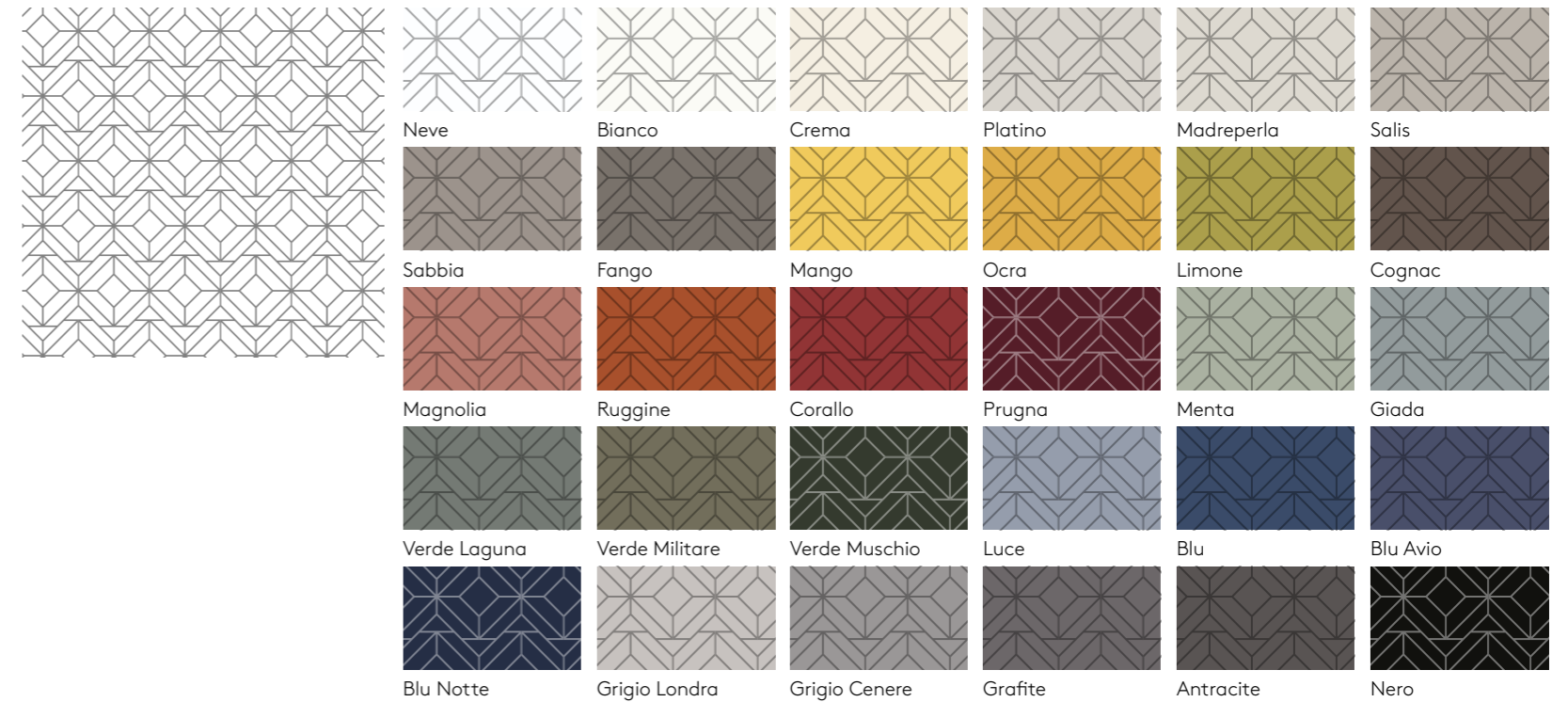

N.B. : Per disponibilità finitura nei vari articoli consultare il listino prezzi/Le finiture ed i colori sono indicativi e possono subire variazioni dovute alla tecnica di stampa
 N.B. Refer to the price list for the possible finishes of the various items/The finishes and colours are for illustration only and may vary due to the printing technique

VEGA DAY

Programma spalla/Open-end Shelving System

Prof. **35,5 e 48,3 cm** (compresi frontali - fronts included)

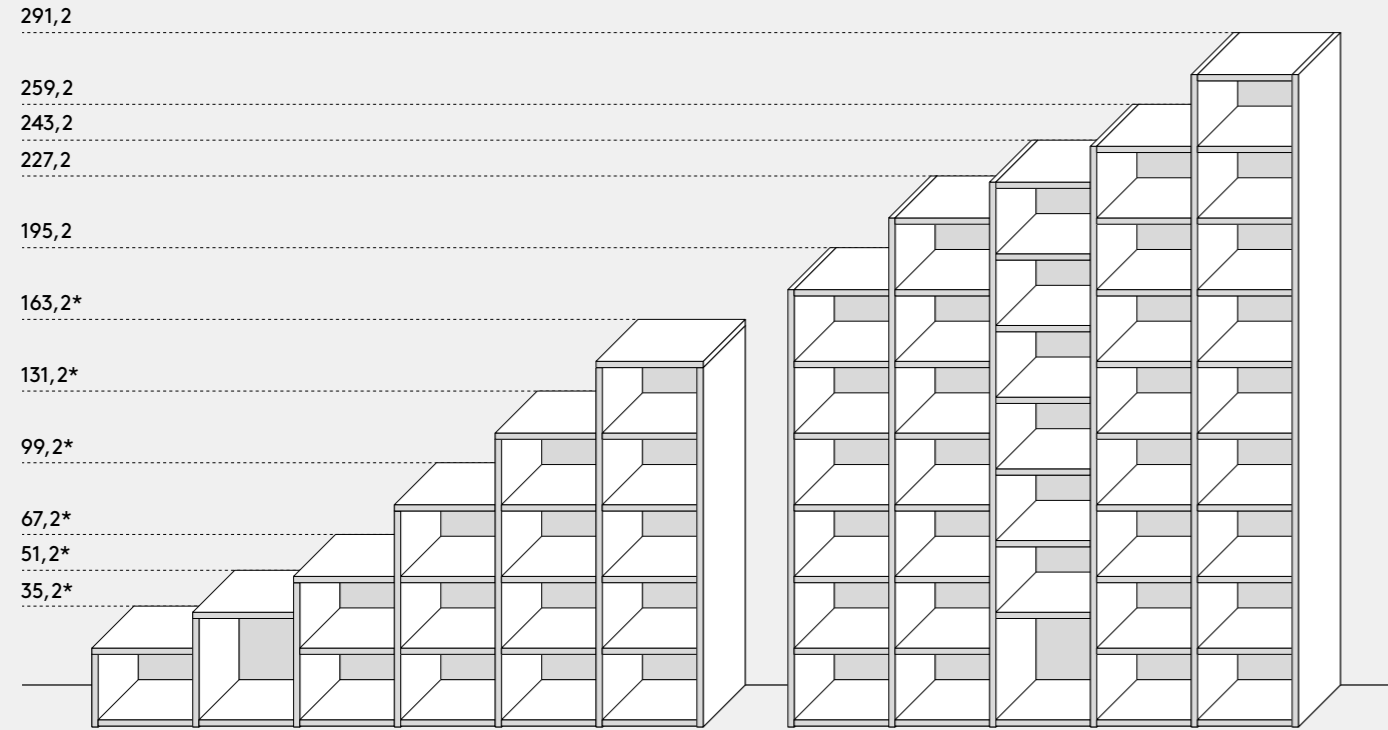

Prof. **60 cm** (compresi frontali - fronts included)

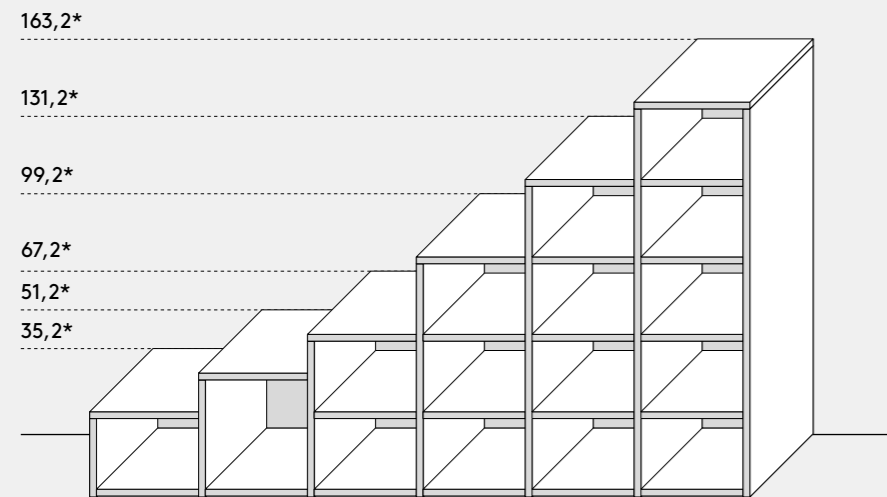

* Coperchio Unico fino a H. 163,2 cm.
Le composizioni Vega Day vengono fornite con coperchio unico fissato alle spalle (L. max 291 cm)

* Unico top up to 163.2 cm in height
The Vega Day compositions are supplied with a one-piece top fastened to the sides (max. width 291 cm)

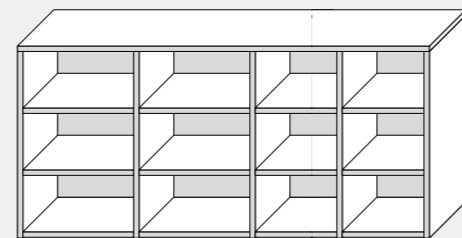

Larghezze
(compresa spalla sx)

Widths
(left side included)

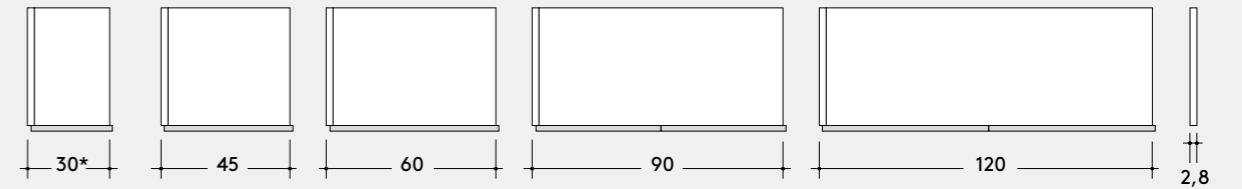

* esclusa prof. 60 cm / * 60 cm. depth excluded

Profondità
(compresi frontali)

Depths
(fronts included)

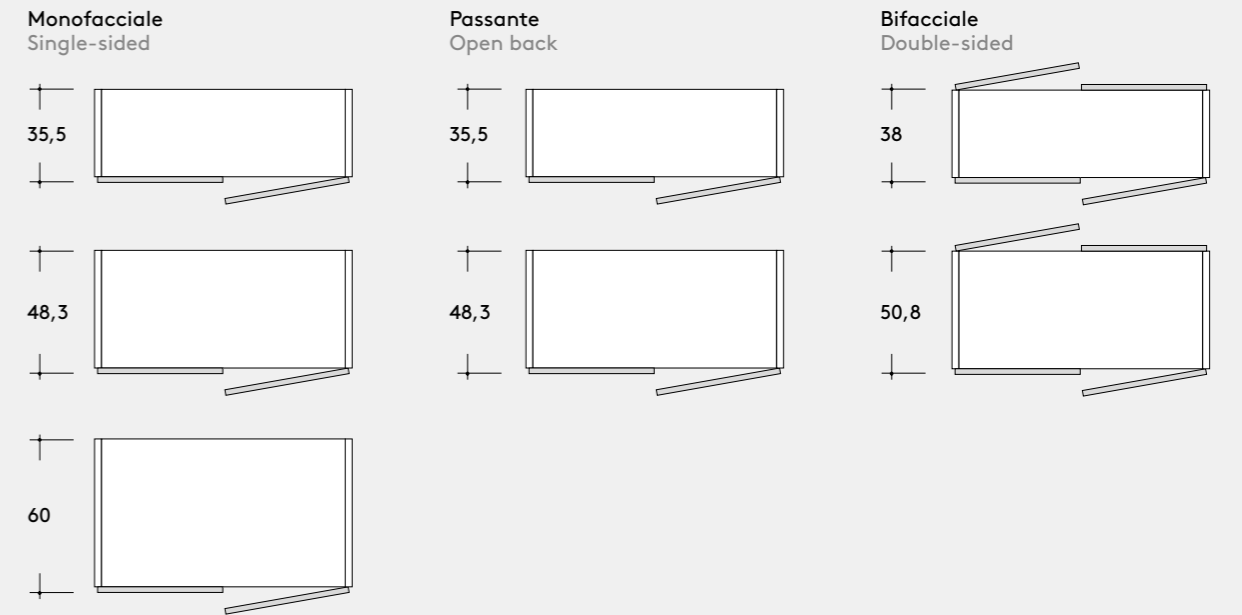

Angoli
(compresa spalla sx e frontali)

Corners
(left side and fronts included)

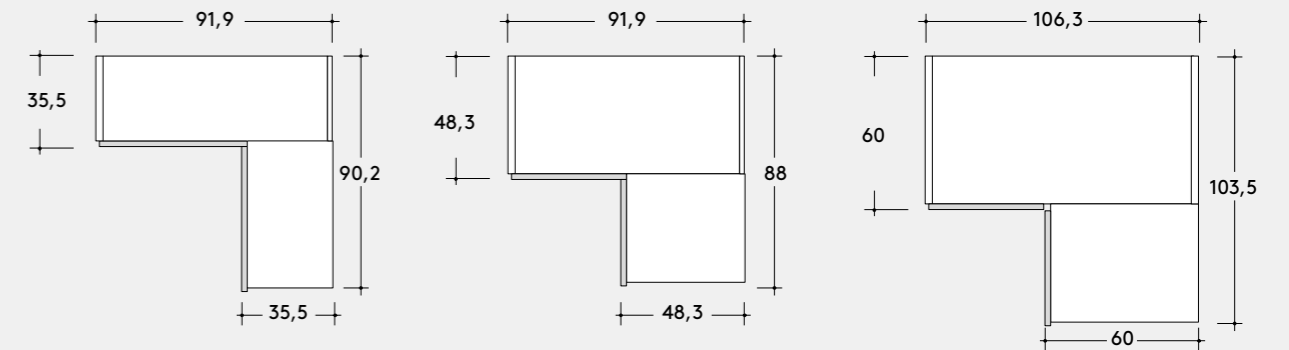

Terminali
(compresa spalla sx e frontali)

End units
(left side and fronts included)

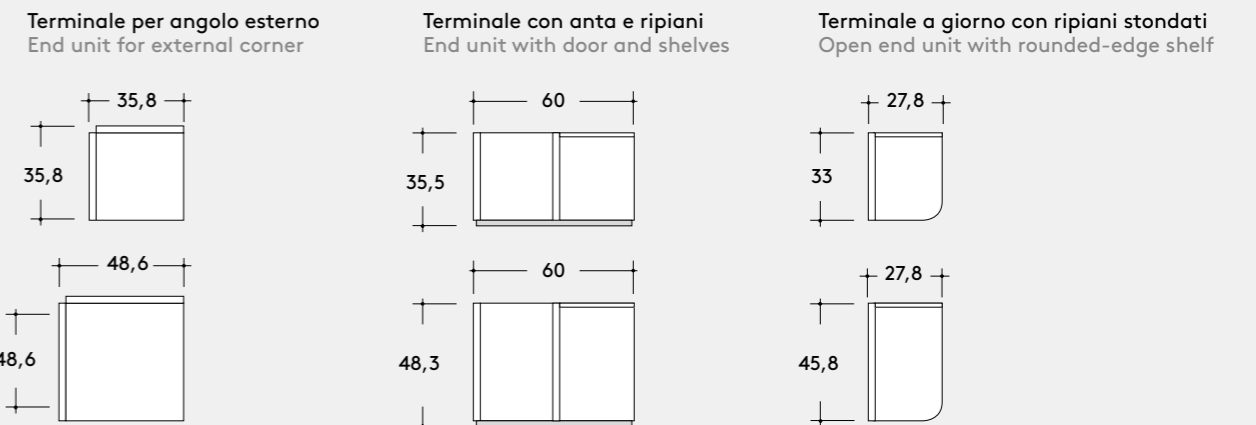

VEGA DAY MAXI VEGA DAY MAXI CON DIVISORI IN CRISTALLO

Programma spalla/Open-end Shelving System

Prof. 33 e 45,8 cm (struttura - frame)

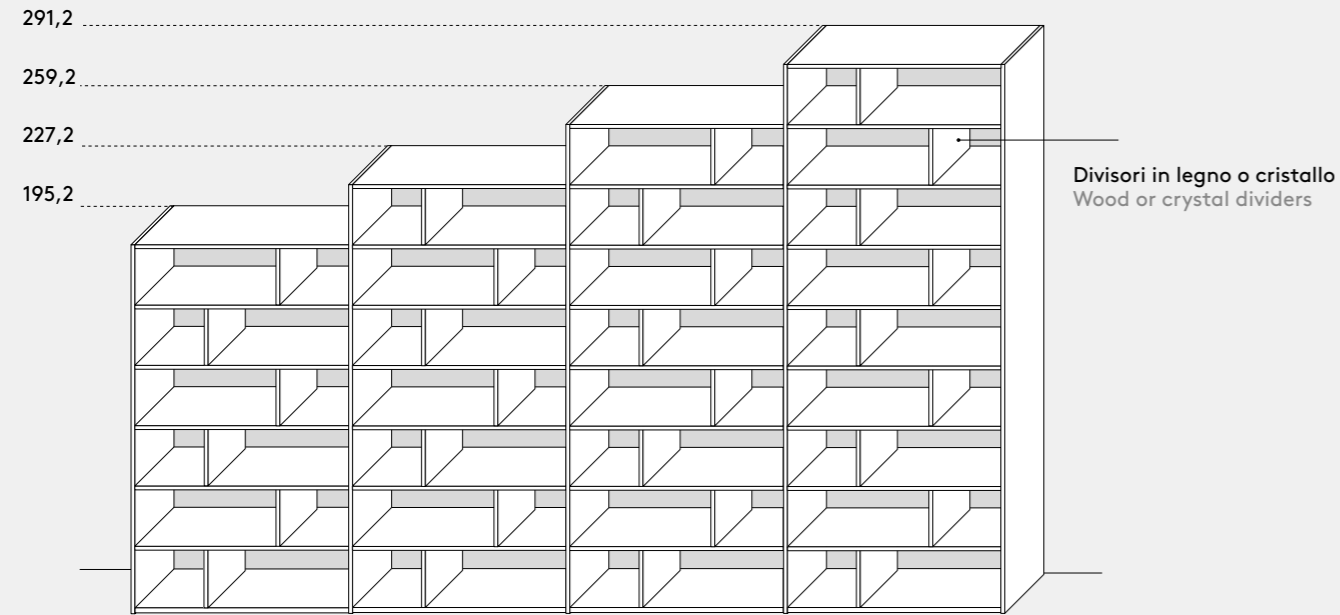

Larghezze
(compresa spalla sx)

Widths
(left side included)

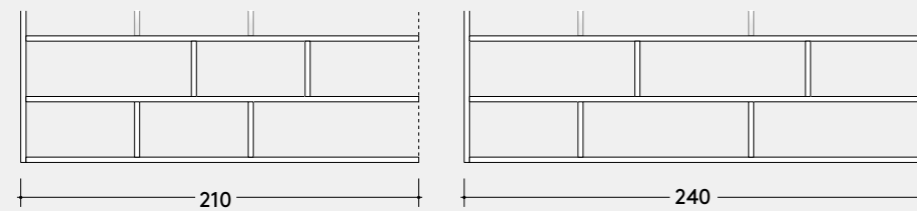
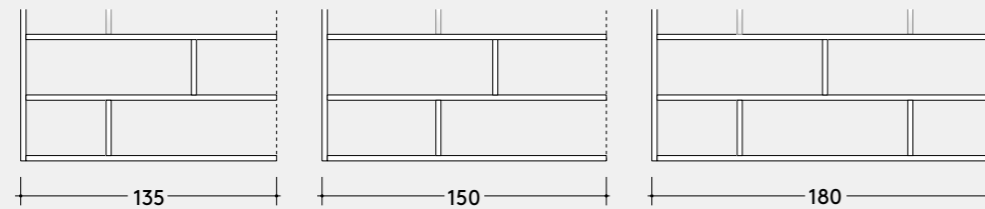

Profondità
Depths

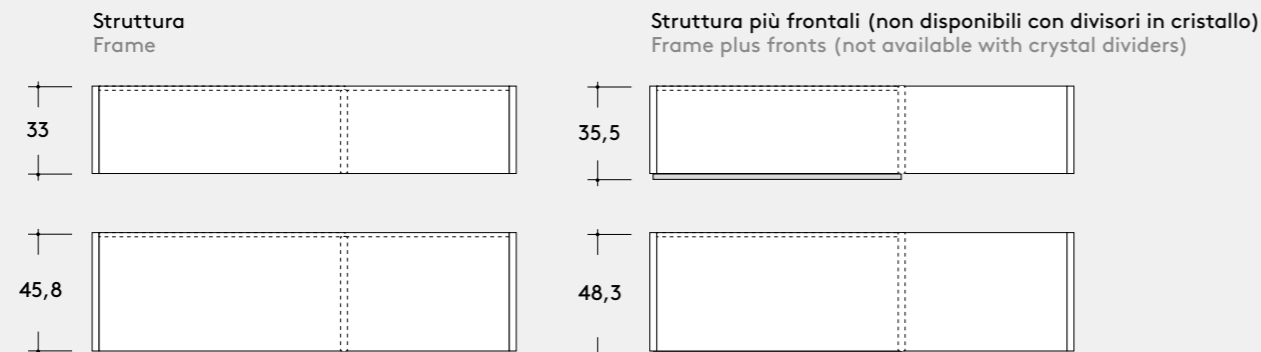

ELEMENTI SOVRAPPOSTI VEGA DAY

Programma spalla/Open-end Shelving System

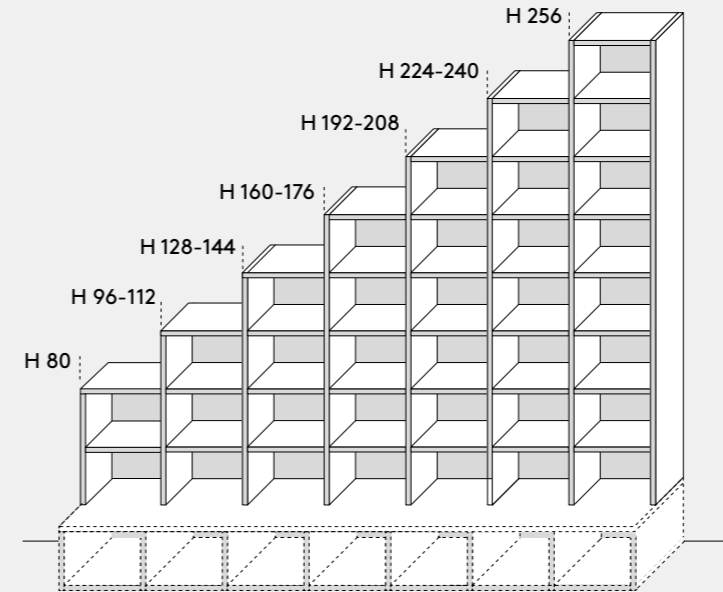

Elementi H 80-96-112-128 cm dotati di coperchio unico
Elemento H 128 disponibile nelle varianti con coperchio in luce o coperchio unico
80-96-112-128 cm high elements equipped with one-piece top / 128 cm high element available with single tops or a one-piece top

Larghezze
(compresa spalla sx)

Widths
(left side included)

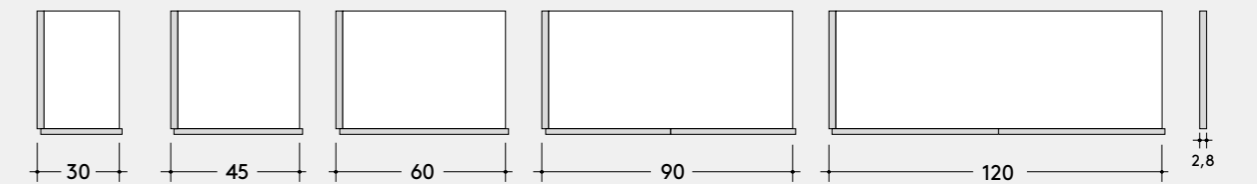

Profondità elementi sovrapposti
(compresi frontali)

Depths of overlapping elements
(fronts included)

Monofacciale / Passante
Single-sided / Open back

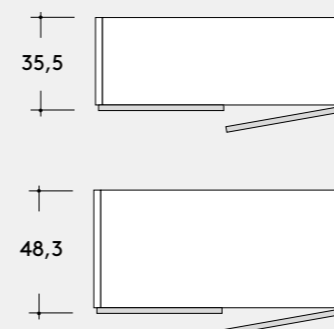

ELEMENTI SOSPESI VEGA DAY

Programma spalla/Open-end Shelving System

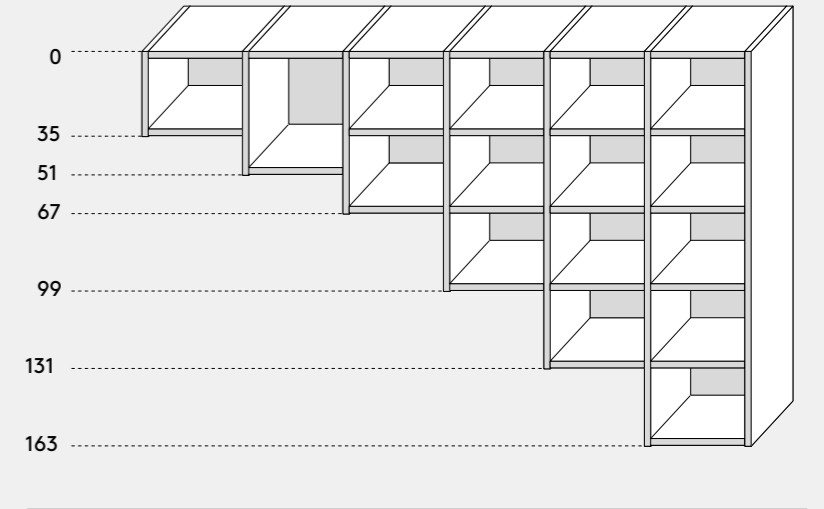

Profondità elementi sospesi
(compresi frontali)

Depths of suspended elements
(fronts included)

Con schiena / Senza schiena
With back / Without back

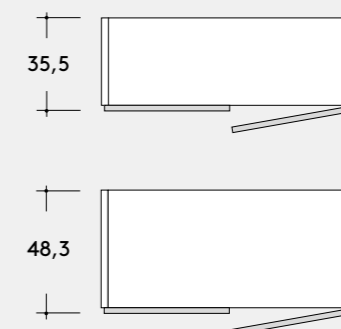

VEGA NIGHT

Programma spalla/Open-end Shelving System

Prof. 60 cm (compresi frontali - fronts included)

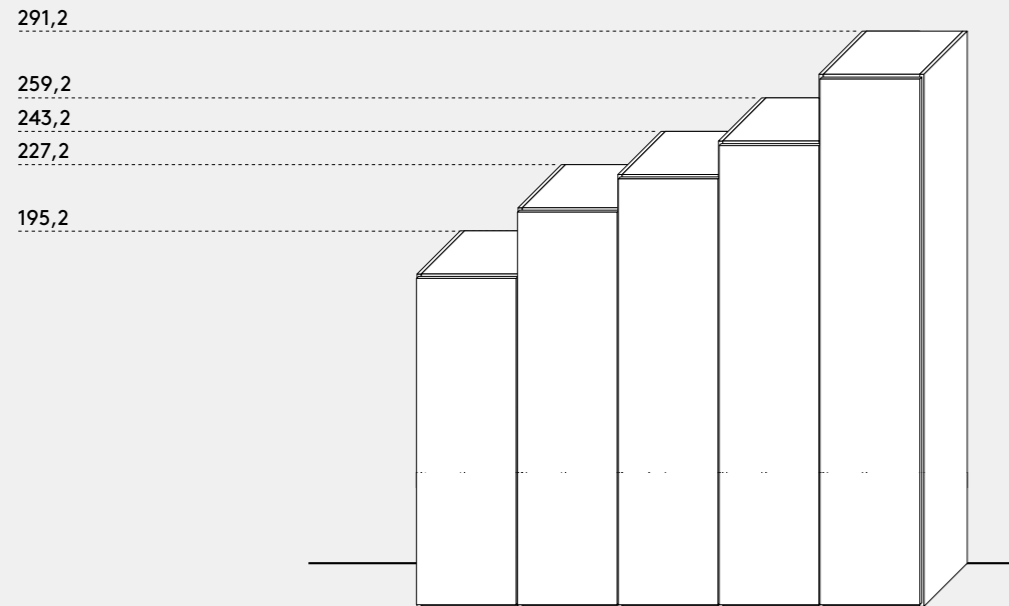

Larghezze
(compresa spalla sx)

Profondità
(compresi frontali)

Widths
(left side included)

Depths
(fronts included)

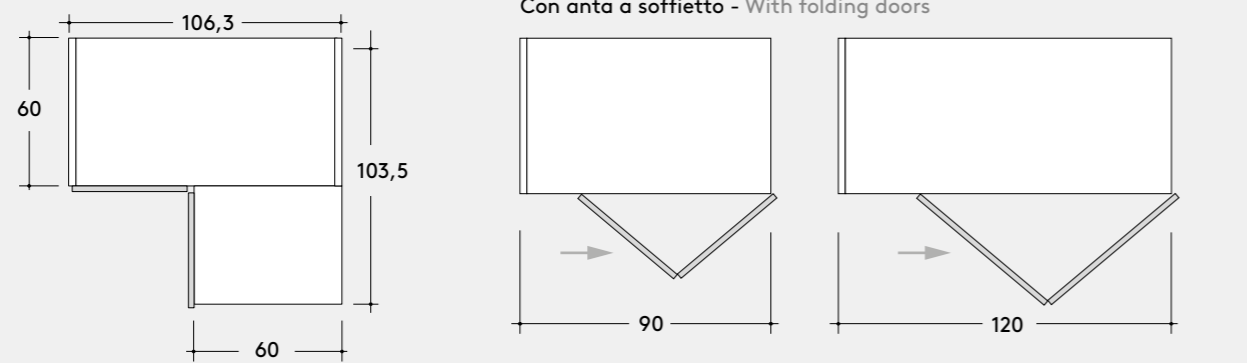
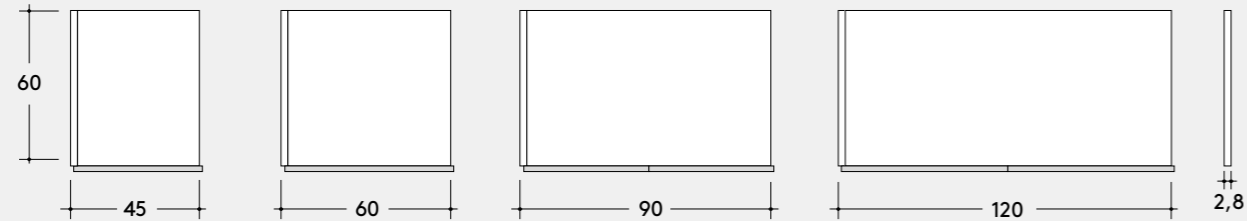

Terminale obliquo
Oblique-cut end unit

Terminale con anta e ripiani
- With door and shelves

Terminale con ripiani stondati
- With rounded-edge shelf

Coprilavatrice (escluso altezza 291,2)
Washing machine cabinet (291.2 cm height excluded)

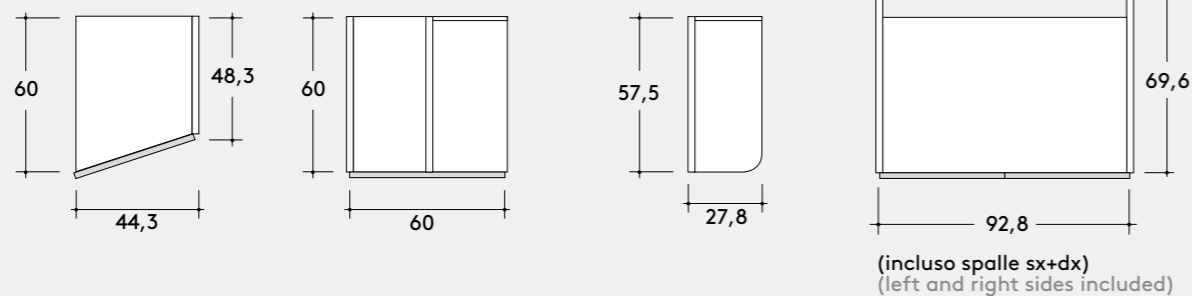

ELEMENTI UNIVERSALI

Programma contenitori/Storage Systems

Utilizzo a terra (con piedini regolabili) in appoggio o sospesi - Floor-mounted (with adjustable feet) or suspended

Altezze
Heights

Larghezze
Widths

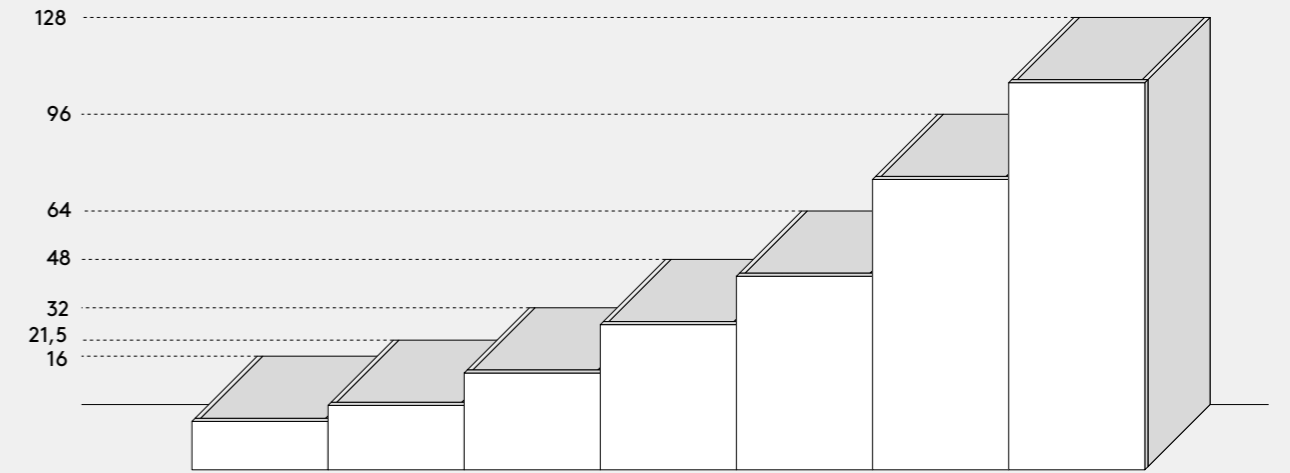

45	45 **	30 *	30 *	30 *	30 *	30 *
60	60 **	45	45	45	45	45
90	90 **	60	60	60	60	60
120	120 **	90	90	90	90	90
	135 **	120	120	120		
	150 **	135 ***				
	180 **	150 ***				
		180 ***				

* Disponibili solo Prof. 34,4 cm - * Only depth available: 34.4 cm

** Disponibili solo Prof. 47,2 cm. Elementi L. 135-150-180 solo con cassetto doppio vano -
** Only depth available: 47.2 cm. 135-150-180 cm deep elements only with double drawer

*** Disponibili solo Prof. 34,4 e 47,2 cm con cassettone doppio vano, anta basculante e ribalta -
*** Only depths available: 34.4 and 47.2 cm with double big drawer, up and over and flap door

Profondità
(compresi frontali)

Depths
(fronts included)

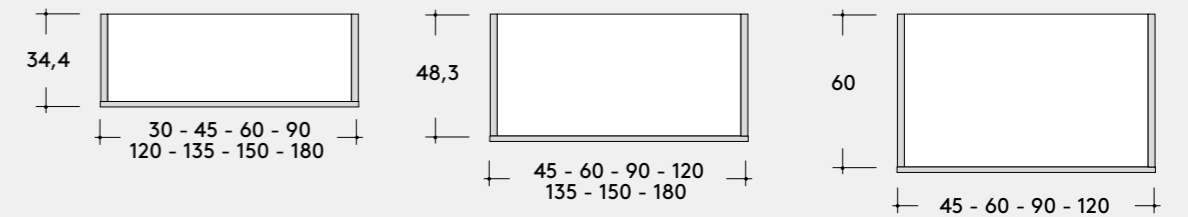

APERTURE ELEMENTI UNIVERSALI / UNIVERSAL ELEMENT OPENINGS

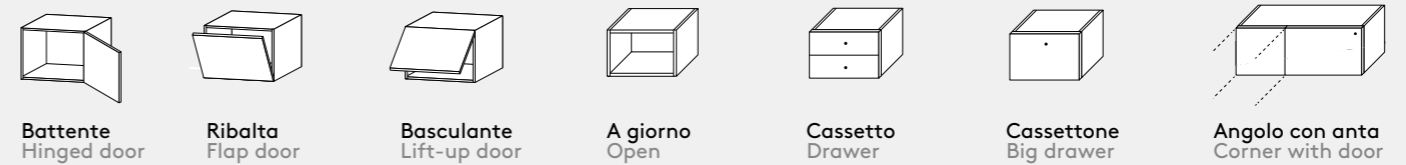

Elementi con vassoio
Vassoio with element

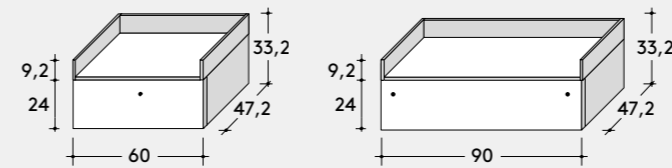

ELEMENTI I-LINE

I-Line element

Utilizzo a terra (con piedini regolabili) in appoggio o sospesi
Floor-mounted (with adjustable feet) or suspended

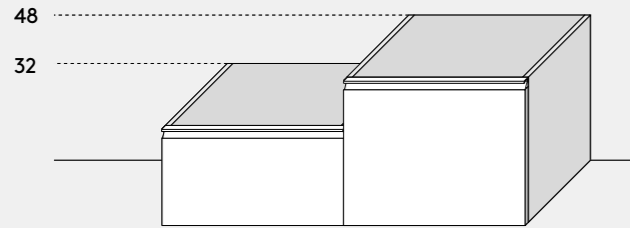

Aperture elementi I-Line
I-Line element openings



Profondità
(compresi frontali)

Depths
(fronts included)

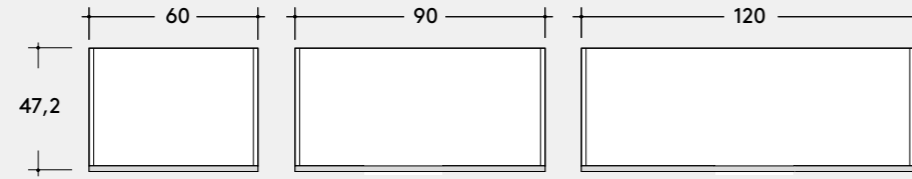

PENSILI / WALL UNITS

PENSILE 1.2/ wall unit 1.2

Prof. 34 cm (disponibile anche con anta, vedi listino - also available with door, see price list)

Sp. 1,2 cm

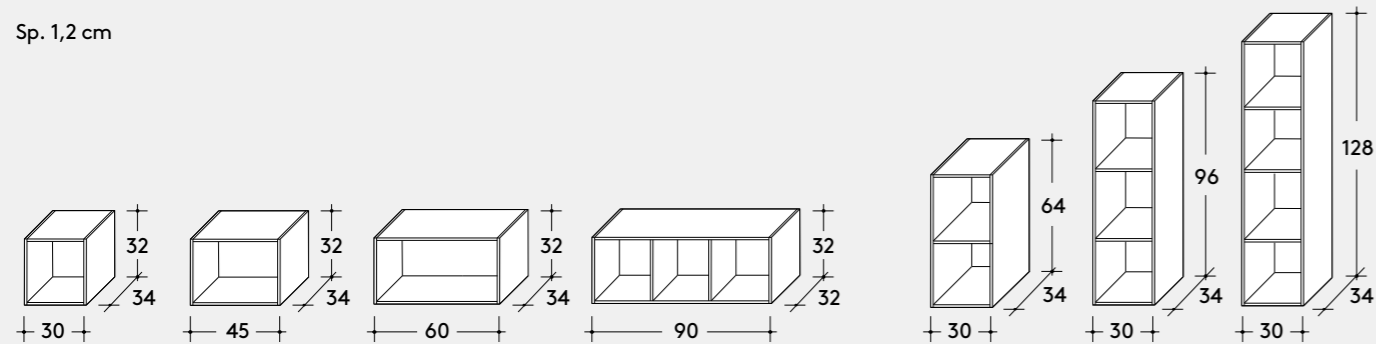

Prof. 46,8 cm

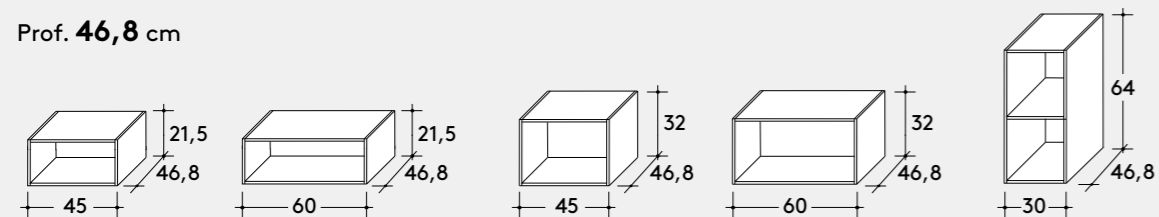

PENSILI / WALL UNITS

PENSILE KUBIK - Wall unit Kubik

Sp. 1,2 cm

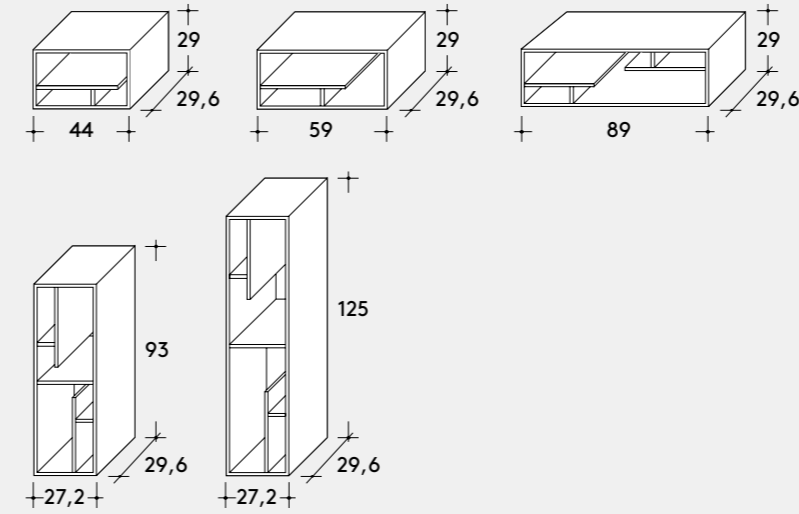

PENSILE KUBIK 2 - Wall unit Kubik 2

Sp. 1,2 cm

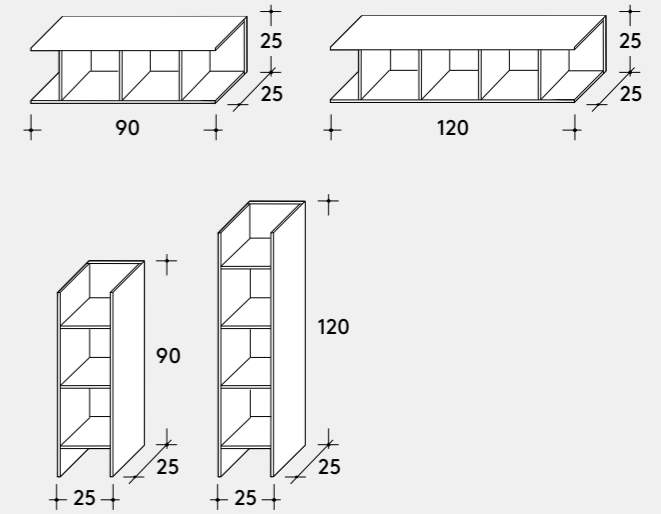

PENSILE TETRIS - Wall unit Tetris

Sp. 1,2 cm

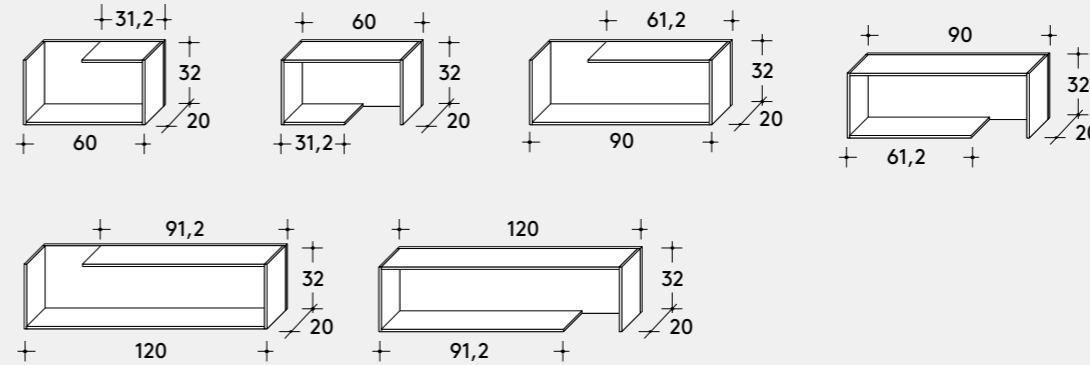

* Gli elementi Tetris possono essere utilizzati solamente a muro, sono reversibili e possono essere abbinati ad elementi universali, pensili 1.2 e mensole Padi
* The Tetris elements must be fastened to the wall, are reversible and can be combined with universal elements, 1.2 wall units and Padi shelves.

PENSILE TETRIS 2 - Wall unit Tetris 2

Sp. 1,2 cm

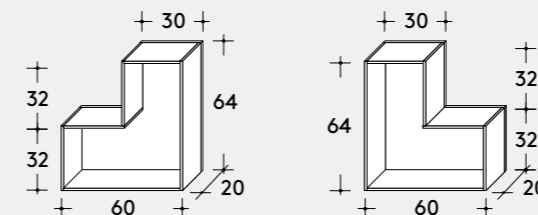

* Gli elementi Tetris possono essere utilizzati solamente a muro, sono reversibili e possono essere abbinati ad elementi universali, pensili 1.2 e mensole Padi
* The Tetris elements must be fastened to the wall, are reversible and can be combined with universal elements, 1.2 wall units and Padi shelves.

ELEMENTI UNIVERSALI E PENSILI

Universal elements and wall units

PENSILE TERMINALE A GIORNO - Open end wall unit

Sp. 1,2 cm

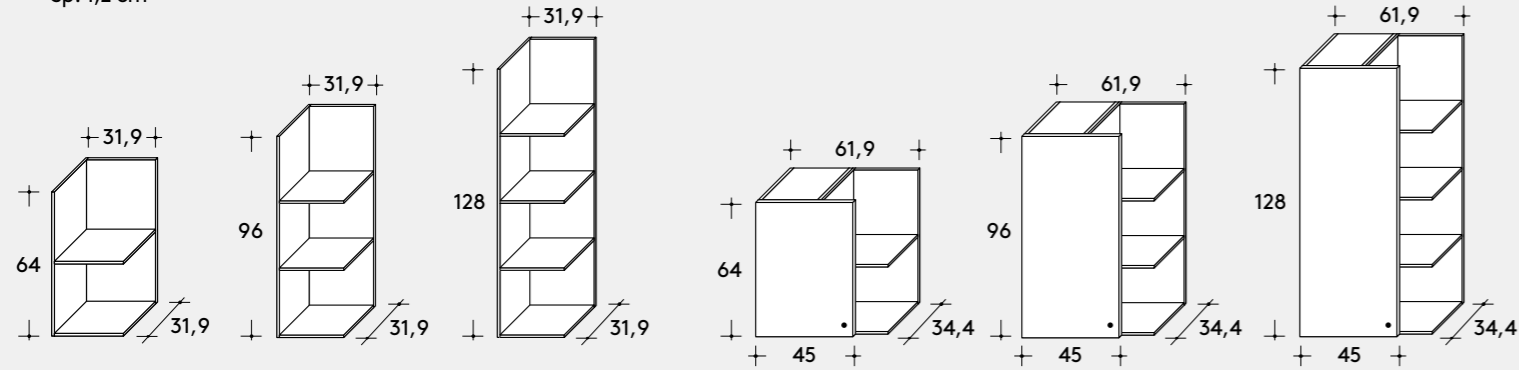

MENSOLE PADI - Padi shelves

Schienale Sp. 1,8 cm, mensola sp. 1,2 cm - Back - 1.8 cm thick / shelf - 1.2 cm thick

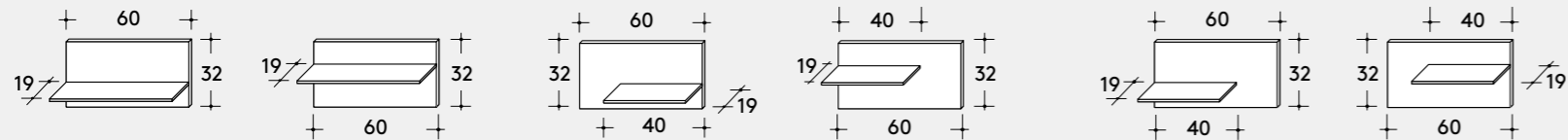

Con mensola in larghezza. Reversibile.
With wide shelf. Reversible.

Con mensola destra. Reversibile.
With right side shelf. Reversible.

Con mensola sinistra. Reversibile.
With left side shelf. Reversible.

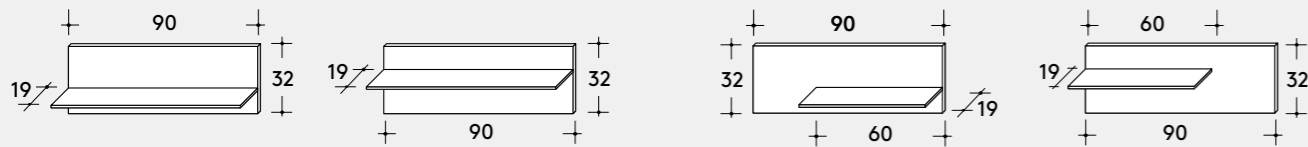

Con mensola in larghezza. Reversibile.
With wide shelf. Reversible.

Con mensola destra. Reversibile.
With right side shelf. Reversible.

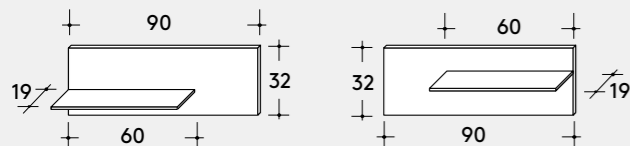

Con mensola sinistra. Reversibile.
With left side shelf. Reversible.

MENSOLA RIO - Rio shelf

In metallo - metal

RIO BASSA - LOW RIO

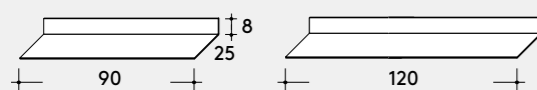

RIO ALTA - HIGH RIO

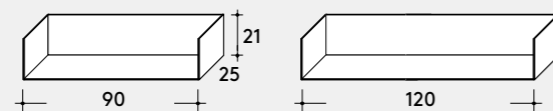

PENSILI E SCAFALE TEKA - Teka wall units and bookcases

Stuttura in tubo metallico - Metal tube frame

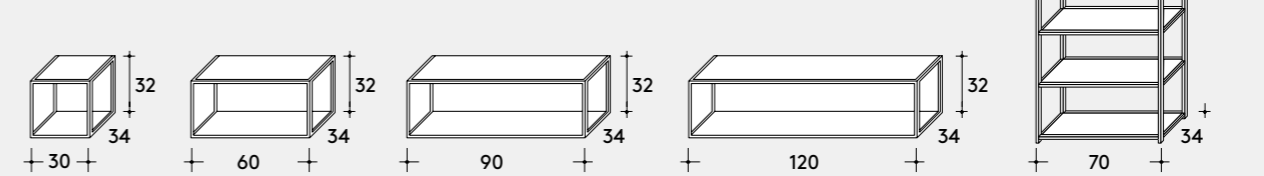

PORTA TV CON MENSOLE - Tv unit with shelves

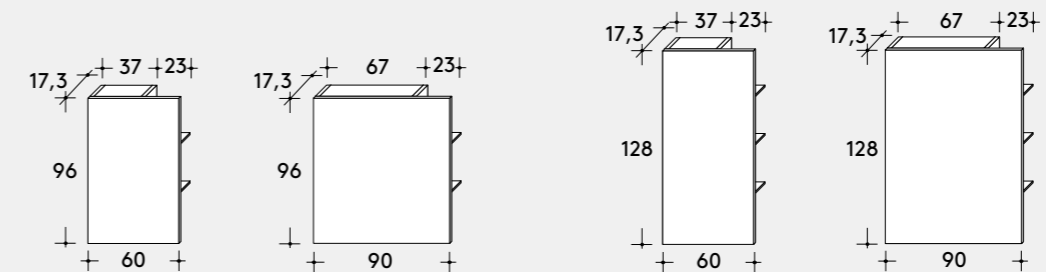

PROGRAMMA SHELL (montanti e mensola) - SHELL SHELVING SYSTEM (uprights and shelves)

In fase di montaggio i montanti possono essere posizionati allineati oppure sfalsati di 5 vm in altezza
During assembly, the uprights can be aligned at the same height or staggered by 5 cm

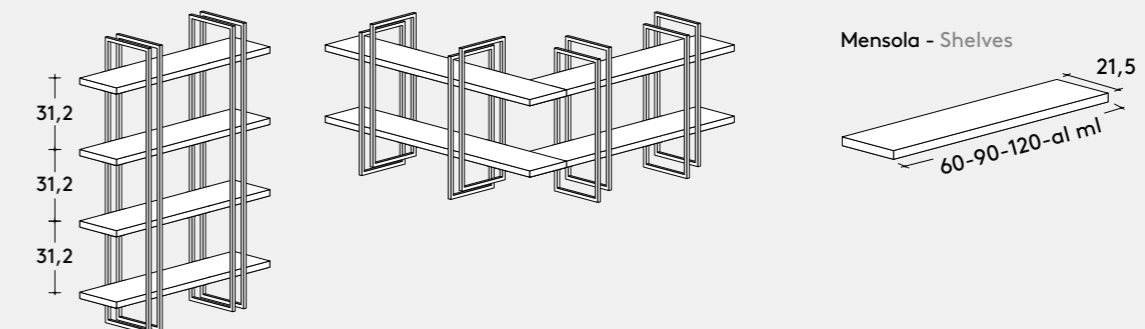
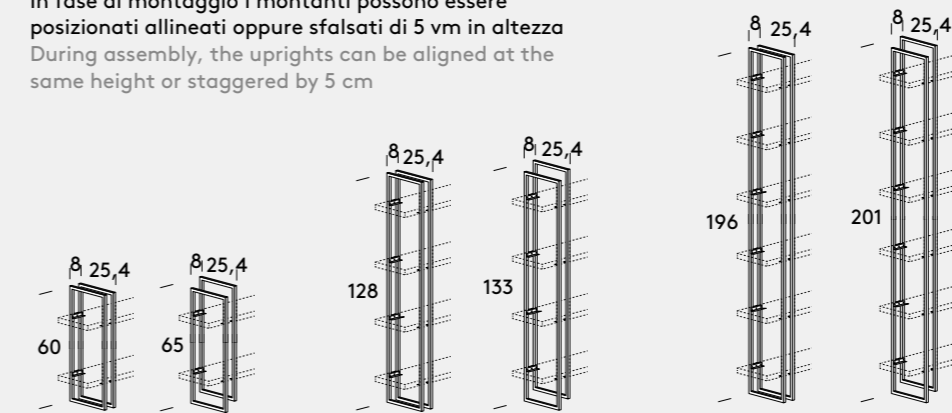

PANNELLI

Holder

PANNELLI CON MODULO ATTREZZATO PER BOISERIE MAX - Holder with equipped elements for boiserie Max

Moduli accostabili - Joinable module

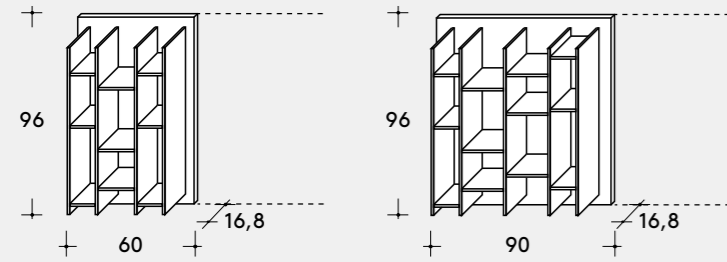

PANNELLI CON MENSOLE PER BOISERIE MAX - Panels with shelves for max panelling

Moduli accostabili - Joinable module

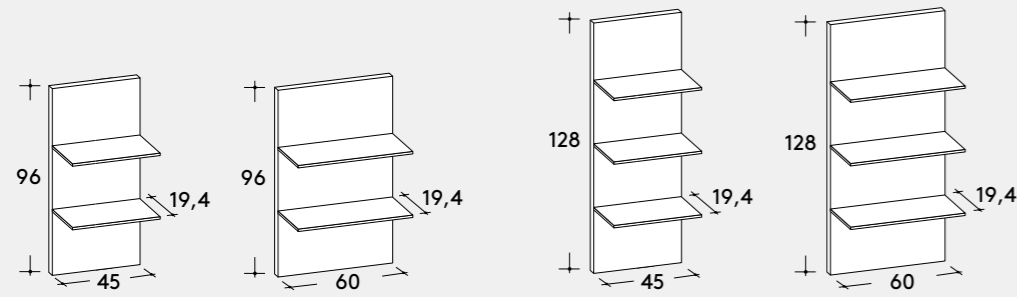

Pagine di sintesi
Summary Pages

Prestige —



Intro Prestige pag. 20

Colonne Vega Day con frontali Axel e colonne Maxi Vega Day con divisori in cristallo - Colonne e ponte Vega Day con frontali Axel - Tavolini Ponte Grande e Happy Island - Poltroncina Nest con basamento - Divano Stile Libero / Vega Day tall units with Axel fronts and Maxi Vega Day tall units with crystal dividers - Vega Day tall units and bridge with Axel fronts - Big Ponte and Happy Island coffee tables - Nest accent chair with swivel base - Stile Libero sofa



Living_801 pag. 24

Colonne Vega Day e colonne Maxi Vega Day con frontali Axel - Tavolino Ponte Piccolo - Tavolo Thor - Sedie MS001 - Divano Queensway / Vega Day tall units and Maxi Vega Day tall units with Axel fronts - Small Ponte coffee table - Thor table - MS001 chairs - Queensway sofa



Living_802 pag. 28

Colonne e ponte Vega Day con frontali Axel - Piano sospeso Jump - Poltroncina Nest con basamento / Vega Day tall units and bridge with Axel fronts - Suspended Jump top - Nest accent chair with swivel base



Living_809 pag. 48

Colonne Vega Day con frontali Axel ed illuminazione Reflex su ripiani vetro - Tavolino Ponte Grande - Poltrona Melody - Tavolo Delta - Sedie Giulia / Vega Day tall units with Axel fronts and Reflex lighting on glass shelves - Big Ponte coffee table - Melody armchair - Delta table - Giulia chairs



Living_810 pag. 52

Elementi universali a terra e sospesi con frontali Axel - Elemento universale a terra con vassoio e frontale Axel - Top Sp.1.2cm - Pensile 1.2 a giorno - Tavolini Teka Rettangolare - Divano Notting-Hill / Floor-mounted and suspended universal elements with Axel fronts - Floor-mounted universal element with tray and Axel fronts - Top - 1.2 cm thick - Open 1.2 wall unit - Rectangular Teka coffee tables - Notting Hill sofa



Living_811 pag. 56

Elementi universali a terra e sospesi con frontali Axel - Top Sp.1.2cm - Pannello Boiserie Max attrezzato con mensole - Tavolino Happy Island - Divano Wild / Floor-mounted and suspended universal elements with Axel fronts - Top - 1.2 cm thick - Equipped Max panelling with shelves - Happy Island coffee table - Wild sofa



Living_803 pag. 32

Colonne Vega Day con frontali Axel, Anta Vetro ed illuminazione Reflex su ripiani vetro - Tavolo Otello - Sedie MS001 / Vega Day tall units with Axel and Glass Door fronts and Reflex lighting on glass shelves - Otello table - MS001 chairs



Living_804 pag. 34

Colonne, basi ed elementi sospesi Vega Day con ante scorrevoli Axel - Tavolino Zippo Rettangolare - Divano Notting-Hill / Vega Day tall units, bases and suspended elements with Axel sliding doors - Rectangular Zippo coffee table - Notting Hill sofa



Living_805 pag. 38

Boiserie Stripe con mensola Sp.1.2cm - Elementi universali sospesi con frontali Axel - Top Sp.1.2cm - Pensile 1.2 a giorno - Tavolini Teka Rotondo - Divano Notting-Hill / Stripe panelling with 1.2 cm thick shelves - Suspended universal elements with Axel fronts - Top - 1.2 cm thick - Open 1.2 wall unit - Round Teka coffee tables - Notting Hill sofa



Living_812 pag. 60

Elementi universali sospesi con frontali Axel - Piano sospeso Jump con alzata - Pannello Boiserie Max attrezzato con mensole - Tavolino Happy Island / Suspended universal elements with Axel fronts - Suspended Jump top with riser - Equipped Max panelling with shelves - Happy Island coffee table



Living_813 pag. 62

Elementi universali sospesi con frontali Axel - Top Sp.1.2cm - Pensili 1.2 a giorno - Boiserie Max - Divano e pouf Queensway / Suspended universal elements with Axel fronts - Top - 1.2 cm thick - Open 1.2 wall units - Max panelling - Queensway sofa and pouf



Living_814 pag. 66

Elementi universali a terra con frontali Axel - Top Sp.1.2cm - Elementi universali sospesi con Anta Vetro ed illuminazione Reflex su ripiani vetro - Piano sospeso Jump con fianco di sostegno - Tavolini Teka Rettangolare e Happy Island - Poltrone Wild / Floor-mounted universal elements with Axel fronts - Top - 1.2 cm thick - Suspended universal elements with Glass Doors and Reflex lighting on glass shelves - Suspended Jump top with side support - Rectangular Teka and Happy Island coffee tables - Wild armchairs



Living_806 pag. 43

Elementi universali sospesi con frontali Axel - Top Sp.1.2cm - Elementi universali sospesi con Anta Vetro ed illuminazione Reflex su ripiani vetro - Mensole Padi con schienale - Sedie Giulia - Tavolo Thor / Suspended universal elements with Axel fronts - Top - 1.2 cm thick - Suspended universal elements with Glass Doors and Reflex lighting on glass shelves - Padi shelves with back - Giulia chairs - Thor table



Living_807 pag. 44

Elementi universali sospesi con frontale Stone/Axel ed illuminazione con strip led - Top Sp.1.2cm - Pensili Kubik 2 - Pouf Notting-Hill / Suspended universal elements with Stone/Axel fronts and led-strip lighting - Top - 1.2 cm thick - Kubik 2 wall units - Notting Hill pouf



Living_808 pag. 46

Colonne Vega Day - Poltrona Queensway Vega Day tall units - Queensway armchair

Modern —



Intro Modern pag. 72

Elementi universali a terra e sospesi con frontali Axel - Elementi a terra I-line - Top Sp.1.2cm - Mensole Rio Bassa con illuminazione strip led - Colonne Vega Day e colonne Maxi Vega Day con divisori in cristallo - Tavolo Thor - Poltroncina Nest con slitta - Divano e pouf Queensway / Floor-mounted and suspended universal elements with Axel fronts - Top - 1.2 cm thick - Floor-mounted I-line elements - Low Rio shelves with led-strip lighting - Vega Day and Maxi Vega Day tall units with crystal dividers - Thor table - Nest accent chairs with sled base - Queensway sofa and pouf



Living_817 pag. 84

Elementi universali sospesi con Anta Vetro - Top Sp.1.2cm - Mensola Sp.2.8cm con supporti Litio - Tavolo Otello - Poltroncina Nest con slitta / Suspended universal elements with Glass Doors - Top - 1.2 cm thick - 2.8 cm thick shelf with concealed Litio shelf supports - Otello table - Nest accent chair with sled base



Living_820 pag. 92

Elementi I-Line a terra - Top Sp.1.2cm - Pensili Kubik - Elementi universali sospesi e pensili terminali a giorno con frontali Axel - Colonne Vega Day - Tavolino Rotondo - Divano e pouf Greenwich / Floor-mounted I-Line elements - Top - 1.2 cm thick - Kubik wall units - Suspended universal elements and open-end units with Axel fronts - Vega Day tall units - Rotondo coffee table - Greenwich sofa and pouf



Living_815 pag. 76

Elementi universali a terra e sospesi con frontali Axel - Top Sp.1.2cm - Pensili 1.2 a giorno - Piano sospeso Jump con fianco di sostegno - Divano Wild / Floor-mounted and suspended universal elements with Axel fronts - Top - 1.2 cm thick - Open 1.2 wall units - Suspended Jump top with side support - Wild sofa



Living_818 pag. 87

Madia Regolo con basamento - Mensole Rio Alta con illuminazione strip led / Regolo sideboard with base - Tall Rio shelves with led-strip lighting



Living_821 pag. 96

Elementi universali sospesi con frontali Axel - Top Sp.1.2cm - Boiserie Max - Mensole Rio Bassa con illuminazione strip led - Madia Regolo con basamento - Tavolini Teka Rettangolare e Teka Rotondo - Divano Notting-Hill / Suspended universal elements with Axel fronts - Top - 1.2 cm thick - Max panelling - Low Rio shelves with led-strip lighting - Regolo sideboard with base - Rectangular and round Teka coffee tables - Notting Hill sofa



Living_816 pag. 80

Elementi universali a terra con frontali Creek - Top Sp.1.2cm - Elementi universali sospesi con frontali Axel - Pensili Kubik 2 - Tavolino Rotondo - Poltrone e pouf Queensway / Floor-mounted universal elements with Creek fronts - Top - 1.2 cm thick - Suspended universal elements with Axel fronts - Kubik 2 wall units - Rotondo coffee table - Queensway armchairs and pouf



Living_819 pag. 88

Elementi universali a terra con frontali Axel - Top Sp.1.2cm - Elementi universali sospesi con Anta Vetro - Madia Zelig sospesa - Tavolino Rotondo - Divano e pouf Greenwich / Floor-mounted universal elements with Axel fronts - Top - 1.2 cm thick - Suspended universal elements with Glass Doors - Suspended Zelig sideboard - Rotondo coffee table - Greenwich sofa and pouf



Living_822 pag. 100

Elementi universali sospesi con frontali Axel - Pensili 1.2 a giorno - Tavolino Teka Rettangolare / Suspended universal elements with Axel fronts - Open 1.2 wall units - Rectangular Teka coffee table



pag. 102

Colonne Maxi Vega Day con frontali Axel - Colonna Vega Day passante - Elementi universali sospesi con frontali Axel - Top Sp.1.2cm - Boiserie Max - Mensole Sp.2.8cm con supporti Litio - Tavolo e panca Thor - Sedia Giulia / Maxi Vega Day tall units with Axel fronts - Open back Vega Day tall units - Suspended universal elements with Axel fronts - Top - 1.2 cm thick - Max panelling - 2.8 cm thick shelves with concealed Litio shelf supports - Thor table and bench - Giulia chairs



Living_825 pag. 108

Colonne Maxi Vega Day con divisorio in cristallo - Colonna passante Vega Day - Tavolino Teka Rotondo - Tavolo Zippo - Sedie Cloe - Divano e pouf Queensway / Maxi Vega Day tall units with crystal dividers - Open back Vega Day tall units - Round Teka coffee table - Zippo table - Cloe chairs - Queensway sofa and pouf



Living_828 pag. 120

Elementi universali a terra e sospesi con frontali Axel - Top Sp.1.2cm - Pensili Kubik 2 - Tavolo Otello - Sedie Nest con slitta / Floor-mounted and suspended universal elements with Axel fronts - Top - 1.2 cm thick - Kubik 2 wall units - Otello table - Nest accent chairs with sled base



Living_823 pag. 104

Elementi universali sospesi con frontali Axel - Top Sp.1.2cm - Boiserie Max - Mensole Sp.2.8cm con supporti Litio - Tavolini Teka Rotondo - Poltrona Wild / Suspended universal elements with Axel fronts - Top - 1.2 cm thick - Max panelling - 2.8 cm thick shelves with concealed Litio shelf supports - Round Teka coffee tables - Wild armchair



Living_826 pag. 112

Colonne Vega Day con frontali Stone, Axel, anta vetro Sestante ed illuminazione Reflex su ripiani vetro - Tavolino Happy Island - Tavolo Diamante - Sedia Cloe - Pouf Notting-Hill / Vega Day tall units with Stone and Axel fronts and Sestante glass door and Reflex lighting on glass shelves - Happy Island coffee table - Diamante table - Cloe chairs - Notting Hill pouf



Living_829 pag. 124

Elementi universali sospesi con frontali Axel - Top Sp.1.2cm - Pensili 1.2 a giorno - Boiserie Max - Madia Regolo con basamento - Tavolini Teka Rettangolare - Divano Queensway / Suspended universal elements with Axel fronts - Top - 1.2 cm thick - Open 1.2 wall units - Max panelling - Regolo sideboard with base - Rectangular Teka coffee tables - Queensway sofa



Living_824 pag. 106

Colonne Maxi Vega Day con frontali Axel - Colonna passante Vega Day - Elementi universali sospesi con frontali Axel - Top Sp.1.2cm - Boiserie Max / Maxi Vega Day tall units with Axel fronts - Open back Vega Day tall units - Suspended universal elements with Axel fronts - Top - 1.2 cm thick - Max panelling



Living_827 pag. 118

Elementi universali sospesi con frontali Axel - Top Sp.1.2cm - Piano sospeso Jump - Boiserie Stripe con mensola Sp.1.2cm - Tavolini Teka Rotondo - Divano Queensway / Suspended universal elements with Axel fronts - Top - 1.2 cm thick - Suspended Jump top - Strip panelling with 1.2 cm thick shelves - Round Teka coffee tables - Queensway sofa

Loft —



Intro Loft pag. 130

Elementi universali sospesi con frontali Axel - Top Sp.1.2cm - Pensili 1.2 a giorno - Boiserie Max con pannello attrezzato con mensole ed illuminazione strip led - Mensole Padi con schienale - Colonne Vega Day con ante scorrevoli e battenti Axel - Tavolini Teka Rotondo - Divano e pouf stile libero
Suspended universal elements with Axel fronts - Top - 1.2 cm thick - Open 1.2 wall units - Max panelling equipped with shelves and led-strip lighting - Padi shelves with back - Vega Day tall units with Axel sliding and wing doors - Round Teka coffee tables - Stile Libero sofa and pouf



Living_830 pag. 134

Elementi universali sospesi con frontali Axel - Top Sp.1.2cm - Pensili 1.2 a giorno - Boiserie Max con pannello attrezzato con mensole ed illuminazione strip led - Madia sospesa Trim - Tavolini Happy Island / Suspended universal elements with Axel fronts - Top - 1.2 cm thick - Open 1.2 wall units - Max panelling equipped with shelves and led-strip lighting - Suspended Trim sideboard - Happy Island coffee tables



Living_831 pag. 138

Colonne Vega Day con ante scorrevoli e battenti Axel - Elementi universali sospesi con frontali Axel - Top Sp.1.2cm - Mensole Rio Bassa con illuminazione strip led / Vega Day tall units with Axel sliding and wing doors - Suspended universal elements with Axel fronts - Top - 1.2 cm thick - Low Rio shelves with led-strip lighting



Living_838 pag. 158

Elementi universali sospesi con frontali Axel - Top Sp.1.2cm - Pensili Teka / Suspended universal elements with Axel fronts - Top - 1.2 cm thick - Teka wall units



Living_839 pag. 160

Elementi universali sospesi con frontali Axel - Top Sp.1.2cm - Mensole Padi con schienale - Spalle sospese in metallo Shell con mensole Sp.2.8cm - Tavolini Teka Rotondo - Divano Queensway / Suspended universal elements with Axel fronts - Top - 1.2 cm thick - Padi shelves with back - Suspended Shell open bookcase with 2.8 cm thick shelves - Round Teka coffee tables - Queensway sofa



Living_840 pag. 164

Elementi universali a terra, sospesi e pensili terminali a giorno con frontali Axel - Top Sp.1.2cm Floor-mounted and suspended universal elements and open end wall units with Axel fronts - Top - 1.2 cm thick



Living_832 pag. 141

Elementi universali sospesi con frontali Axel - Top Sp.1.2cm - Mensole Rio Bassa con illuminazione strip led / Suspended universal elements with Axel fronts - Top - 1.2 cm thick - Low Rio shelves with led-strip lighting



Living_833 pag. 142

Colonne Vega Day con anta vetro Sestante ed illuminazione Led retro ripiano - Colonne Vega Day sospese con frontali Axel - Tavolo Thor - Sedie Nest con slitta - Tavolino Gamba Inclinata Vega Day tall units with Sestante glass doors and led lighting behind shelves - Suspended Vega Day tall units with Axel fronts - Thor table - Nest accent chairs with sled base - Gamba Inclinata coffee table



Living_834 pag. 145

Colonne Vega Day sospese con frontali Axel / Suspended Vega Day tall units with Axel fronts



Living_841 pag. 166

Elementi universali sospesi con frontali Axel - Top Sp.1.2cm - Pensili Kubik 2 / Suspended universal elements with Axel fronts - Top - 1.2 cm thick - Kubik 2 wall units



Living_835 pag. 146

Basi, colonne ed elementi sovrapposti Vega Day con frontali Axel - Boiserie Max - Madie sospese Trim - Divano e pouf Wild / Vega Day bases, tall units and overlapping elements with Axel fronts - Max panelling - Suspended Trim sideboards - Wild sofa and pouf



Living_836 pag. 150

Basi Vega Day con frontali Stone - Colonne passanti ed elementi sovrapposti passanti Vega Day - Tavolo Delta - Sedie Cloe / Vega Day bases with Stone fronts - Vega Day open back tall units and open back overlapping elements - Delta table - Cloe chairs



Living_837 pag. 154

Elementi I-Line a terra - Top Sp.1.2cm - Elemento universale sospeso con frontali Axel - Mensole Padi con schienale / Floor-mounted I-Line elements - Top - 1.2 cm thick - Suspended universal element with Axel fronts - Padi shelves with back

Young —

**Intro Young** pag. 170

Elementi universali a terra e sospesi con frontali Axel - Top Sp.1.2cm - Pensili e scaffali Teka - Spalle sospese in metallo Shell con mensole Sp.2.8cm - Tavolini Zippo Rotondo - Tavolo Otello - Sedie Elena con gambe - Divano e pouf Queensway / Floor-mounted and suspended universal elements with Axel fronts - Top - 1.2 cm thick - Teka bookcases and wall units - Suspended Shell open bookcase with 2.8 cm thick shelves - Round Zippo coffee tables - Otello table - Elena chairs with leg base - Queensway sofa and pouf??

**Living_842** pag. 174

Elementi universali a terra e sospesi con frontali Axel - Top Sp.1.2cm - Pensili Teka - Tavolino Gamba Inclinata - Divano Queensway / Floor-mounted and suspended universal elements with Axel fronts - Top - 1.2 cm thick - Teka wall units - Gamba Inclinata coffee table - Queensway sofa

**Living_843** pag. 178

Scaffali Teka - Colonne Vega Day - Tavolo Jolly - Sedia Tata / Teka bookcases - Vega Day tall units - Jolly table - Tata chairs

**Living_850** pag. 202

Elementi universali a terra con frontali Creek - Elementi universali sospesi con frontali Axel - Pensile Kubik 2 - Top Sp.1.2cm - Piano sospeso Jump con fianco di sostegno - Madia Creek con basamento - Tavolino Gamba Inclinata - Sedia Nest con basamento - Divano Queensway / Floor-mounted universal elements with Creek fronts - Suspended universal elements with Axel fronts - Kubik 2 wall unit - Top - 1.2 cm thick - Suspended Jump top with side support - Creek sideboard with base - Gamba Inclinata coffee table - Nest accent chair with swivel base - Queensway sofa

**Living_851** pag. 206

Elementi Vega Day sospesi con frontali Axel - Piano sospeso Jump con alzata - Sedia Tata / Suspended Vega Day elements with Axel fronts - Suspended Jump top with riser - Tata chairs

**Living_852** pag. 208

Spalle sospese in metallo Shell con mensole Sp.2.8cm - Tavolino Teka Rettangolare - Divano Queensway / Suspended Shell open bookcase with 2.8 cm thick shelves - Rectangular Teka coffee table - Queensway sofa

**Living_844** pag. 182

Basi, elementi sovrapposti e colonne Maxi Vega Day con frontali Axel - Tavolino Rotondo - Tavolo Thor - Sedia Sirio / Maxi Vega Day bases, overlapping elements and tall units with Axel fronts - Rotondo coffee table - Thor table - Sirio chairs

**Living_845** pag. 186

Elementi sospesi Vega Day con frontali Axel - Tavolini Teka Rettangolare - Tavolo Otello - Sedia Cloe - Divano Queensway / Suspended Vega Day elements with Axel fronts - Rectangular Teka coffee tables - Otello table - Cloe chairs - Queensway sofa

**Living_846** pag. 188

Elementi universali e a terra e sospesi con frontali Axel - Top Sp.5.6cm - Top Sp.1.2cm con alzatina - Tavolo Thor - Sedie Cloe - Tavolini Happy Island - Divano Queensway / Floor-mounted and suspended universal elements with Axel fronts - Top - 5.6 cm thick - Top - 1.2 cm thick with riser - Thor table - Cloe chairs - Happy Island coffee tables - Queensway sofa

**Living_853** pag. 212

Elementi universali sospesi con frontali Axel - Top Sp.1.2cm - Pensili Teka / Suspended Shell open bookcase with 2.8 cm thick shelves - Suspended Zelig sideboard - Diamante table - Emi chairs

**Living_847** pag. 192

Elementi universali sospesi con frontali Axel - Pensile 1.2 a giorno - Top Sp.1.2cm - Piano sospeso Jump - Mensole Rio Alta con illuminazione strip led - Madie sospese Trim - Tavolo Delta - Sedie Cloe - Tavolini Teka Rotondo - Divano Wild / Suspended universal elements with Axel fronts - Open 1.2 wall unit - Top - 1.2 cm thick - Suspended Jump top - Tall Rio shelves with led-strip lighting - Suspended Trim sideboards - Delta table - Cloe chairs - Round Teka coffee tables - Wild sofa

**Living_848** pag. 196

Elementi universali sospesi con frontali Axel - Pensile 1.2 a giorno - Top Sp.1.2cm - Piano sospeso Jump - Tavolino Teka Rotondo / Suspended universal elements with Axel fronts - Open 1.2 wall unit - Top - 1.2 cm thick - Suspended Jump top - Round Teka coffee table

**Living_849** pag. 198

Elementi universali sospesi con frontali Axel - Elementi universali sospesi con vassoio e frontale Axel - Pensili Tetris 2 - Mensola Padi con schienale - Top Sp.1.2cm - Tavolini Teka Rotondo - Divano Wild / Suspended universal elements with Axel fronts - Suspended universal elements with tray and Axel fronts - Tetris 2 wall units - Padi shelf with back - Top - 1.2 cm thick - Round Teka coffee tables - Wild sofa

Nordic —



Intro Nordic pag. 216

Elementi universali e sospesi con frontali Axel - Top Sp.1.2cm - Pensili Tekka - Elementi Vega Day sospesi con frontali Axel - Boiserie Max (pannello con specchio e pannello con appendiabiti) - Colonne Maxi Vega Day con divisori in cristallo - Tavolini Zippo Quadro - Tavolo Zippo - Sedie Sirio - Divano Wild / Universal and suspended elements with Axel fronts - Top - 1.2 cm thick - Tekka wall units - Suspended Vega Day elements with Axel fronts - Max panelling (panel with mirror and panel with coat rack) - Maxi Vega Day tall units with crystal dividers - Square Zippo coffee tables - Zippo table - Sirio chairs - Wild sofa



Living_854 pag. 220

Elementi universali sospesi con frontali Axel - Top Sp.1.2cm - Pensili Tekka - Tavolo Thor / Suspended universal elements with Axel fronts - Top - 1.2 cm thick - Tekka wall units - Thor table



Living_855 pag. 222

Elementi Vega Day sospesi con frontali Axel - Divano Queensway / Suspended Vega Day elements with Axel fronts - Queensway sofa



Living_862 pag. 242

Elementi universali a terra e sospesi con frontali Axel - Top Sp.1.2cm - Piano Sp.5.6cm con fianco di sostegno - Mensola Padi con schienale / Floor-mounted and suspended universal elements with Axel fronts - Top - 1.2 cm thick - Top - 5.6 cm thick with side support - Padi shelf with back



Living_863 pag. 244

Basi e colonne Vega Day con frontali Axel - Boiserie Max con illuminazione strip led - Mensole Sp.2.8cm con supporti Litio - Elementi universali sospesi con Anta Vetro - Top Sp.1.2cm - Tavolino Zippo Quadrato / Vega Day bases and tall units with Axel fronts - Max panelling with led-strip lighting - 2.8 cm thick shelves with concealed Litio shelf supports - Suspended universal elements with Glass Doors - Top - 1.2 cm thick Square Zippo coffee table



Living_856 pag. 225

Elementi universali sospesi con frontali Axel - Pensili Tekka - Tavolo Otello - Sedie Tata / Suspended universal elements with Axel fronts - Tekka wall units - Otello table - Tata chairs



Living_857 pag. 226

Elementi universali sospesi con frontali Axel - Pensili Tekka - Piani sospesi Jump - Tavolino Zippo Rettangolare - Divano Wild / Suspended universal elements with Axel fronts - Tekka wall units - Suspended Jump tops - Rectangular Zippo coffee table - Wild sofa



Living_858 pag. 228

Colonne Vega Day con frontali Axel - Colonne Vega Night con frontali Omega - Tavolo Thor - Sedie Tata - Pouf Queensway / Vega Day tall units with Axel fronts - Vega Night tall units with Omega fronts - Thor table - Tata chairs - Queensway pouf



Living_859 pag. 232

Elementi I-Line a terra - Top Sp.1.2cm - Mensole Rio Bassa e Rio Alta con illuminazione strip led - Tavolino Rotondo - Divano Queensway / Floor-mounted I-Line elements - Top - 1.2 cm thick - High and low Rio shelves with led-strip lighting - Rotondo coffee table - Queensway sofa



Living_860 pag. 236

Elementi universali a terra e sospesi con frontali Axel - Pensili Kubik 2 - Top Sp.1.2cm - Piano sospeso Jump con fianco di sostegno - Tavolino Zippo Rettangolare - Divano Wild / Floor-mounted and suspended universal elements with Axel fronts - Kubik 2 wall units - Top - 1.2 cm thick - Suspended Jump top with side support - Rectangular Zippo coffee table - Wild sofa



Living_861 pag. 240

Elementi universali sospesi con frontali Axel - Top Sp.1.2cm - Colonne Vega Day - Tavolo Otello - Sedie Jenny Imbottita / Suspended universal elements with Axel fronts - Top - 1.2 cm thick - Vega Day tall units - Otello table - Padded Jenny chairs



SPAGNOLmobili

MOBIL S.r.l.

Via Vidor, 1
31010 Mosnigo di Moriago
(Treviso) ITALY

Tel. +39 0438 89 11
Fax +39 0438 89 00 82
E-mail mobili@spagnol.it
Web www.spagnol.it
Web www.spagnolmobili.it

EXPORT DEPARTMENT

Tel. +39 0423 98 87
Fax +39 0423 98 88 36
E-mail export@spagnol.it



© MOBIL S.r.l.



L'azienda si riserva di apportare senza preavviso modifiche tecnico-costruttive, nei materiali e nelle finiture, tali da non pregiudicare le caratteristiche essenziali del prodotto descritto o illustrato. I colori ed i materiali rappresentati nelle immagini hanno valore indicativo in quanto soggetti alle tolleranze dei processi di stampa.

Company reserves the right to make unannounced technical and structural changes, in materials and finishes, such as not undermine the essential characteristics of the described and illustrated product. Colors and materials shown in the pictures are indicative as they are depending on the tolerances of the printing process.



SPAGNOLmobili



Mobil S.r.l. - Spagnol Mobili

Via Vidor, 1 - 31010 Mosnigo di Moriago (TV) - ITALY

Tel. +39.0438.89.11 - Fax +39.0438.89.00.82

www.spagnol.it - www.spagnolmobili.it - mobili@spagnol.it